

# R.E.S.L

## Richmonds Earl Shilton Limited

Specialist Distributors of Compressors and Refrigeration Spares

### Model: ZR40K3E-PFJ

#### Data

Type: Scroll compressor

Producer: Copeland

Series: ZR

### Technical data

Nominal motor power [HP]:	3,5
Displacement [m <sup>3</sup> /h]:	9,4
Sound pressure level :	57
Gross/Net weight [kg]:	31/27
Oil charge [dm <sup>3</sup> ]:	1,1

### Electrical data

Power supply [V/~/Hz]:	220-240/1/50Hz
Locked rotor current [A]:	100
Max. operating current [A]:	23,1
Winding resistance [ $\Omega$ ]:	1,81/0,75

### Connections

	<u>milimeters</u>	<u>inches</u>
Suction Rotolock valve connection:		-
Discharge Rotolock valve connection:		-
Suction connection with supplied sleeve:		3/4"
Discharge connection with supplied sleeve:		1/2"

# R.E.S.L

## Richmonds Earl Shilton Limited

Specialist Distributors of Compressors and Refrigeration Spares

### Model: ZR40K3E-PFJ

Capacity

R22

#### Cooling capacity [kW]

$t_c \setminus t_e$	-20	-15	-10	-5	0	5	10
30	3.97	4.98	6.15	7.49	9.04	10.82	12.83
35	3.75	4.72	5.85	7.15	8.64	10.35	12.30
40	3.53	4.46	5.54	6.79	8.22	9.87	11.75
45	-	4.19	5.22	6.41	7.79	9.37	11.17
50	-	-	4.88	6.02	7.33	8.85	10.58
55	-	-	-	5.60	6.86	8.30	9.96
60	-	-	-	-	6.35	7.72	9.30
65	-	-	-	-	5.82	7.12	8.62

#### Power input [kW]

$t_c \setminus t_e$	-20	-15	-10	-5	0	5	10
30	1.83	1.83	1.81	1.79	1.77	1.74	1.71
35	2.04	2.03	2.01	1.99	1.97	1.94	1.92
40	2.27	2.26	2.25	2.23	2.20	2.17	2.14
45	-	2.53	2.51	2.49	2.46	2.43	2.40
50	-	-	2.81	2.79	2.76	2.72	2.69
55	-	-	-	3.13	3.09	3.06	3.02
60	-	-	-	-	3.47	3.43	3.38
65	-	-	-	-	3.90	3.85	3.80

# R.E.S.L

## Richmonds Earl Shilton Limited

Specialist Distributors of Compressors and Refrigeration Spares

### Model: ZR40K3E-PFJ

Capacity

#### Current [A]

$t_c \setminus t_e$	-20	-15	-10	-5	0	5	10
30	9.63	9.60	9.55	9.48	9.40	9.30	9.19
35	10.40	10.38	10.33	10.26	10.17	10.07	9.97
40	11.31	11.28	11.23	11.15	11.06	10.96	10.85
45	-	12.35	12.29	12.20	12.10	11.99	11.87
50	-	-	13.52	13.42	13.31	13.18	13.05
55	-	-	-	14.85	14.71	14.56	14.41
60	-	-	-	-	16.34	16.17	15.99
65	-	-	-	-	18.22	18.01	17.81

#### Mass flow [kg/s]

$t_c \setminus t_e$	-20	-15	-10	-5	0	5	10
30	85.10	105.51	128.66	154.94	184.74	218.43	256.41
35	83.79	104.09	127.16	153.38	183.14	216.82	254.81
40	82.23	102.43	125.41	151.57	181.28	214.94	252.94
45	-	100.39	123.28	149.37	179.04	212.68	250.67
50	-	-	120.64	146.66	176.28	209.89	247.88
55	-	-	-	143.32	172.89	206.47	244.45
60	-	-	-	-	168.73	202.27	240.24
65	-	-	-	-	163.69	197.19	235.13

# R.E.S.L

## Richmonds Earl Shilton Limited

Specialist Distributors of Compressors and Refrigeration Spares

**Model: ZR40K3E-PFJ**

Capacity

### C.O.P. [W/W]

$t_c \setminus t_e$	-20	-15	-10	-5	0	5	10
30	2.16	2.73	3.39	4.18	5.12	6.21	7.49
35	1.84	2.33	2.90	3.58	4.38	5.32	6.42
40	1.55	1.97	2.47	3.05	3.74	4.54	5.48
45	-	1.66	2.08	2.58	3.17	3.85	4.66
50	-	-	1.74	2.16	2.66	3.25	3.94
55	-	-	-	1.79	2.22	2.72	3.30
60	-	-	-	-	1.83	2.25	2.75
65	-	-	-	-	1.49	1.85	2.27

### Application range

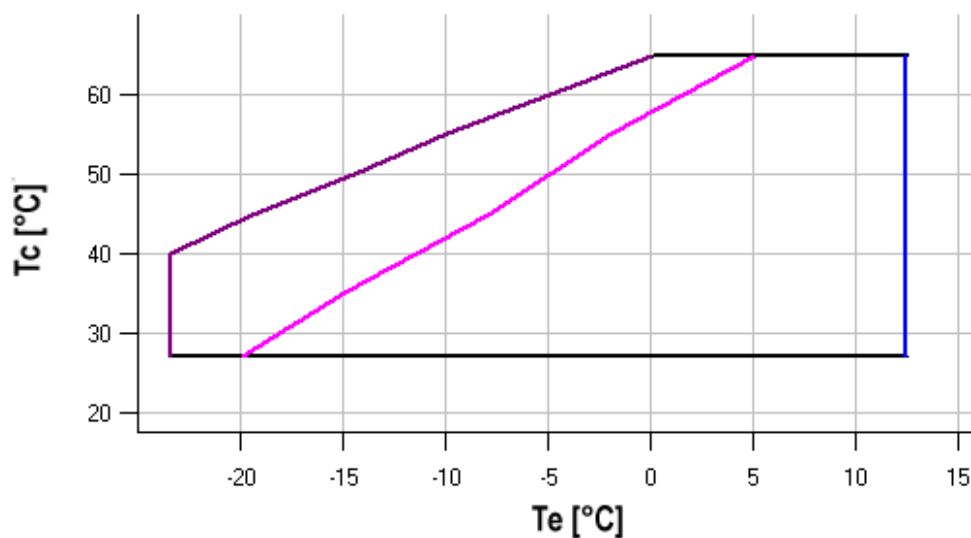

- Maximum evaporating temperature
- 25°C suction gas temperature
- 10K gas overheat

Operating conditions: 10K suction superheat, 0K subcooling

$t_c$  - Condensing temperature [°C]

$t_e$  - Evaporating temperature [°C]

# R.E.S.L

## Richmonds Earl Shilton Limited

Specialist Distributors of Compressors and Refrigeration Spares

### Model: ZR40K3E-PFJ

Capacity

R134a

#### Cooling capacity [kW]

$t_c \setminus t_e$	-20	-15	-10	-5	0	5	10	15
30	2.30	2.94	3.72	4.67	5.79	7.10	8.60	-
35	2.14	2.75	3.51	4.42	5.50	6.75	8.20	-
40	1.99	2.58	3.30	4.17	5.20	6.40	7.79	9.37
45	-	2.40	3.09	3.91	4.89	6.04	7.37	8.88
50	-	2.23	2.88	3.66	4.58	5.67	6.93	8.38
55	-	-	2.66	3.39	4.27	5.30	6.49	7.86
60	-	-	-	3.13	3.94	4.91	6.03	7.33
65	-	-	-	2.85	3.61	4.51	5.56	6.78
70	-	-	-	-	3.27	4.10	5.07	6.21
75	-	-	-	-	2.91	3.67	4.57	5.63

#### Power input [kW]

$t_c \setminus t_e$	-20	-15	-10	-5	0	5	10	15
30	1.35	1.35	1.33	1.30	1.28	1.27	1.30	-
35	1.50	1.51	1.49	1.46	1.43	1.42	1.44	-
40	1.67	1.68	1.66	1.63	1.60	1.58	1.59	1.63
45	-	1.86	1.84	1.82	1.79	1.77	1.77	1.80
50	-	2.05	2.05	2.02	2.00	1.97	1.97	1.99
55	-	-	2.27	2.25	2.23	2.20	2.19	2.21
60	-	-	-	2.50	2.48	2.46	2.45	2.47
65	-	-	-	2.78	2.77	2.75	2.74	2.75
70	-	-	-	-	3.09	3.08	3.07	3.08
75	-	-	-	-	3.44	3.44	3.44	3.45

# R.E.S.L

## Richmonds Earl Shilton Limited

Specialist Distributors of Compressors and Refrigeration Spares

### Model: ZR40K3E-PFJ

Capacity

#### Current [A]

$t_c \setminus t_e$	-20	-15	-10	-5	0	5	10	15
30	8.61	8.56	8.48	8.39	8.31	8.27	8.28	-
35	9.11	9.08	9.01	8.93	8.85	8.80	8.80	-
40	9.65	9.64	9.58	9.51	9.43	9.37	9.36	9.42
45	-	10.27	10.22	10.15	10.08	10.02	10.00	10.05
50	-	10.98	10.95	10.89	10.82	10.77	10.74	10.78
55	-	-	11.79	11.75	11.68	11.63	11.60	11.63
60	-	-	-	12.74	12.68	12.63	12.60	12.62
65	-	-	-	13.89	13.85	13.80	13.77	13.79
70	-	-	-	-	15.20	15.16	15.13	15.14
75	-	-	-	-	16.76	16.73	16.71	16.72

#### Mass flow [kg/s]

$t_c \setminus t_e$	-20	-15	-10	-5	0	5	10	15
30	54.16	67.93	84.47	103.89	126.30	151.81	180.54	-
35	53.19	66.94	83.48	102.92	125.37	150.95	179.77	-
40	52.33	66.03	82.53	101.95	124.41	150.02	178.88	211.13
45	-	65.14	81.57	100.94	123.36	148.96	177.84	210.12
50	-	64.22	80.54	99.82	122.18	147.73	176.58	208.85
55	-	-	79.40	98.55	120.80	146.27	175.06	207.29
60	-	-	-	97.08	119.19	144.53	173.22	205.38
65	-	-	-	95.36	117.28	142.47	171.02	203.06
70	-	-	-	-	115.04	140.02	168.40	200.29
75	-	-	-	-	112.40	137.15	165.32	197.01

# R.E.S.L

## Richmonds Earl Shilton Limited

Specialist Distributors of Compressors and Refrigeration Spares

### Model: ZR40K3E-PFJ

Capacity

#### C.O.P. [W/W]

$t_c \setminus t_e$	-20	-15	-10	-5	0	5	10	15
30	1.70	2.18	2.81	3.60	4.54	5.58	6.62	-
35	1.42	1.83	2.36	3.03	3.84	4.76	5.71	-
40	1.20	1.54	1.99	2.56	3.25	4.04	4.90	5.74
45	-	1.30	1.67	2.15	2.74	3.42	4.17	4.94
50	-	1.09	1.41	1.81	2.30	2.88	3.53	4.21
55	-	-	1.17	1.51	1.92	2.40	2.96	3.55
60	-	-	-	1.25	1.59	1.99	2.46	2.97
65	-	-	-	1.03	1.30	1.64	2.03	2.46
70	-	-	-	-	1.06	1.33	1.65	2.02
75	-	-	-	-	0.85	1.07	1.33	1.63

#### Application range

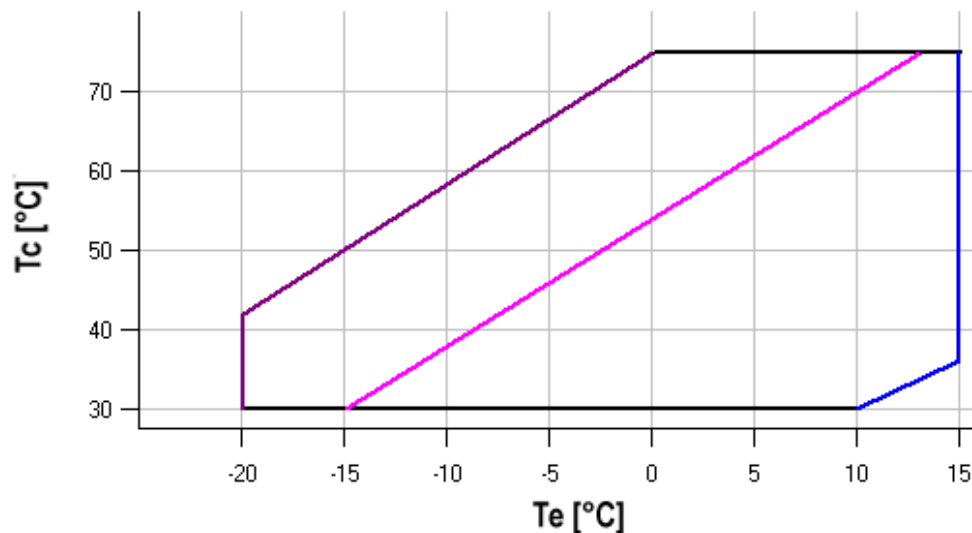

- Maximum evaporating temperature
- 25°C suction gas temperature
- 10K gas overheat

Operating conditions: 10K suction superheat, 0K subcooling

$t_c$  - Condensing temperature [°C]

$t_e$  - Evaporating temperature [°C]

# R.E.S.L

## Richmonds Earl Shilton Limited

Specialist Distributors of Compressors and Refrigeration Spares

### Model: ZR40K3E-PFJ

Capacity

R407C

#### Cooling capacity [kW]

$t_c \setminus t_e$	-20	-15	-10	-5	0	5	10	15
30	3.49	4.50	5.68	7.07	8.68	10.56	12.72	15.20
35	3.25	4.22	5.36	6.69	8.24	10.04	12.12	-
40	3.00	3.93	5.01	6.28	7.76	9.49	11.48	-
45	-	3.62	4.65	5.86	7.26	8.90	10.80	-
50	-	-	4.27	5.40	6.73	8.28	10.08	-
55	-	-	-	4.93	6.17	7.62	9.32	-
60	-	-	-	-	5.58	6.93	8.52	-
65	-	-	-	-	-	6.20	7.67	-

#### Power input [kW]

$t_c \setminus t_e$	-20	-15	-10	-5	0	5	10	15
30	1.80	1.78	1.77	1.76	1.73	1.70	1.64	1.56
35	2.02	2.01	2.00	1.99	1.97	1.93	1.88	-
40	2.26	2.25	2.25	2.24	2.22	2.18	2.13	-
45	-	2.54	2.53	2.52	2.50	2.46	2.41	-
50	-	-	2.87	2.85	2.82	2.78	2.72	-
55	-	-	-	3.25	3.21	3.16	3.09	-
60	-	-	-	-	3.68	3.61	3.53	-
65	-	-	-	-	-	4.15	4.05	-



# R.E.S.L

## Richmonds Earl Shilton Limited

Specialist Distributors of Compressors and Refrigeration Spares

### Model: ZR40K3E-PFJ

Capacity

#### Current [A]

$t_c \setminus t_e$	-20	-15	-10	-5	0	5	10	15
30	8.73	8.66	8.60	8.54	8.44	8.29	8.04	7.69
35	9.65	9.61	9.57	9.53	9.44	9.29	9.05	-
40	10.69	10.66	10.64	10.60	10.52	10.36	10.12	-
45	-	11.89	11.87	11.82	11.73	11.57	11.31	-
50	-	-	13.33	13.28	13.17	12.98	12.69	-
55	-	-	-	15.02	14.89	14.67	14.34	-
60	-	-	-	-	16.96	16.70	16.33	-
65	-	-	-	-	-	19.15	18.72	-

#### Mass flow [kg/s]

$t_c \setminus t_e$	-20	-15	-10	-5	0	5	10	15
30	73.35	93.21	115.90	141.89	171.66	205.70	244.47	288.44
35	71.75	91.60	114.31	140.36	170.21	204.34	243.24	-
40	69.95	89.73	112.39	138.41	168.27	202.44	241.39	-
45	-	87.47	110.01	135.94	165.74	199.87	238.81	-
50	-	-	107.07	132.84	162.50	196.52	235.39	-
55	-	-	-	129.00	158.45	192.29	231.01	-
60	-	-	-	-	153.48	187.07	225.56	-
65	-	-	-	-	-	180.74	218.94	-

# R.E.S.L

## Richmonds Earl Shilton Limited

Specialist Distributors of Compressors and Refrigeration Spares

### Model: ZR40K3E-PFJ

Capacity

#### C.O.P. [W/W]

$t_c \setminus t_e$	-20	-15	-10	-5	0	5	10	15
30	1.94	2.52	3.21	4.02	5.01	6.22	7.76	9.76
35	1.61	2.10	2.68	3.36	4.19	5.19	6.44	-
40	1.33	1.74	2.23	2.81	3.50	4.34	5.39	-
45	-	1.43	1.84	2.32	2.91	3.61	4.49	-
50	-	-	1.49	1.90	2.38	2.98	3.71	-
55	-	-	-	1.52	1.92	2.41	3.02	-
60	-	-	-	-	1.52	1.92	2.41	-
65	-	-	-	-	-	1.49	1.89	-

#### Application range

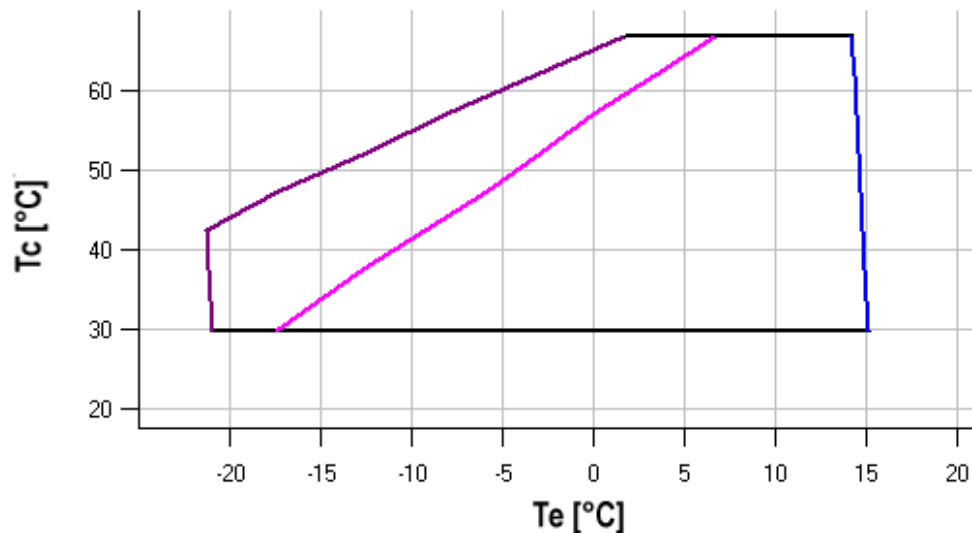

- Maximum evaporating temperature
- 25°C suction gas temperature
- 10K gas overheat

Operating conditions: 10K suction superheat, 0K subcooling

$t_c$  - Condensing temperature [°C]

$t_e$  - Evaporating temperature [°C]

# R.E.S.L

**Richmonds Earl Shilton Limited**

Specialist Distributors of Compressors and Refrigeration Spares

**Model: ZR40K3E-PFJ**

**Dimensions**

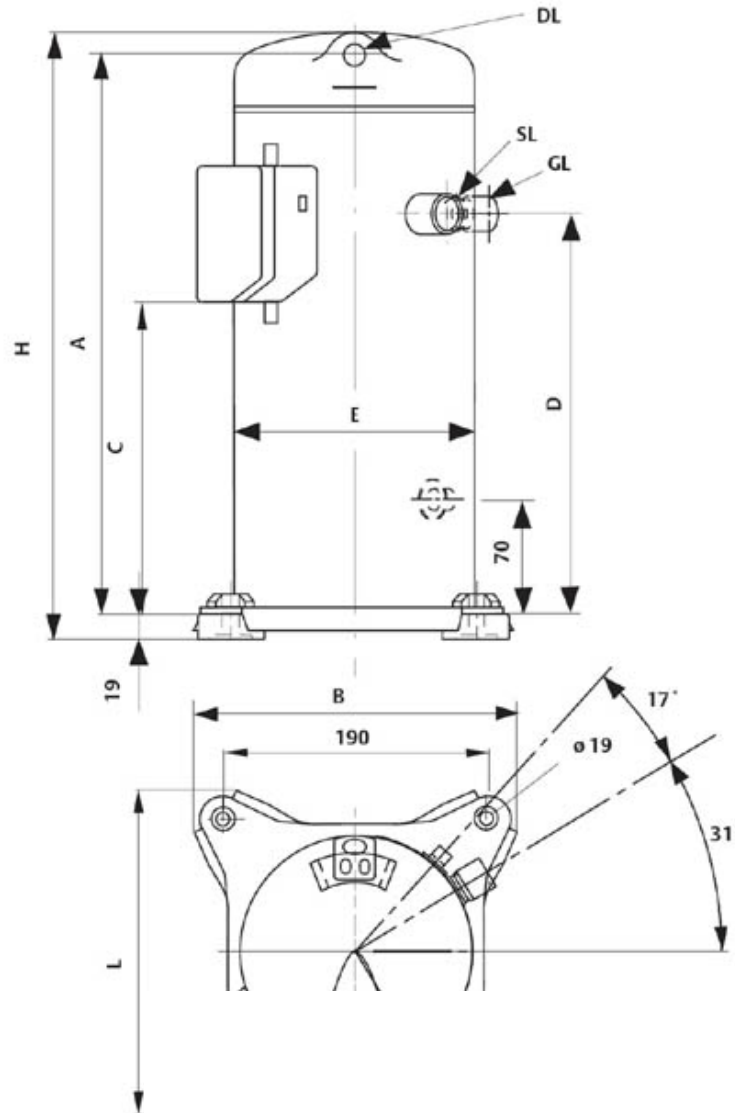

A	375 mm
B	240 mm
C	235 mm
D	277 mm
E	165 mm
H	419 mm
L	231 mm

# R.E.S.L

**Richmonds Earl Shilton Limited**

**Specialist Distributors of Compressors and Refrigeration Spares**

**Model: ZR40K3E-PFJ**

**Image**

