

# R.E.S.L

## Richmonds Earl Shilton Limited

Specialist Distributors of Compressors and Refrigeration Spares

### Model: ZR40K3E-TFD

#### Data

Type: Scroll compressors  
Producer: Copeland  
Series: ZR

#### Technical data

Nominal motor power [HP]:	3,5
Displacement [m <sup>3</sup> /h]:	9,4
Sound pressure level :	57
Gross/Net weight [kg]:	31/27
Oil charge [dm <sup>3</sup> ]:	1,1

#### Electrical data

Power supply [V/~/Hz]:	380-420/3/50Hz
Locked rotor current [A]:	46
Max. operating current [A]:	7
Winding resistance [ $\Omega$ ]:	4,03

#### Connections

	<u>millimeters</u>	<u>inches</u>
Suction Rotolock valve connection:		-
Discharge Rotolock valve connection:		-
Suction connection with supplied sleeve:		3/4"
Discharge connection with supplied sleeve:		1/2"

# R.E.S.L

## Richmonds Earl Shilton Limited

Specialist Distributors of Compressors and Refrigeration Spares

### Model: ZR40K3E-TFD

Capacity

R22

#### Cooling capacity [kW]

$t_c \setminus t_e$	-20	-15	-10	-5	0	5	10
30	3.97	4.98	6.15	7.50	9.04	10.79	12.78
35	3.76	4.73	5.85	7.15	8.63	10.33	12.24
40	3.55	4.47	5.55	6.79	8.22	9.85	11.70
45	-	4.21	5.23	6.42	7.79	9.35	11.13
50	-	-	4.91	6.04	7.35	8.84	10.55
55	-	-	-	5.65	6.89	8.32	9.96
60	-	-	-	-	6.42	7.78	9.34
65	-	-	-	-	5.94	7.22	8.70

#### Power input [kW]

$t_c \setminus t_e$	-20	-15	-10	-5	0	5	10
30	1.79	1.78	1.77	1.75	1.72	1.70	1.67
35	2.00	2.00	1.99	1.97	1.95	1.92	1.89
40	2.24	2.24	2.23	2.21	2.19	2.16	2.13
45	-	2.51	2.50	2.48	2.46	2.43	2.40
50	-	-	2.80	2.78	2.76	2.73	2.69
55	-	-	-	3.12	3.09	3.06	3.02
60	-	-	-	-	3.47	3.43	3.38
65	-	-	-	-	3.88	3.84	3.79

# R.E.S.L

## Richmonds Earl Shilton Limited

Specialist Distributors of Compressors and Refrigeration Spares

### Model: ZR40K3E-TFD

Capacity

#### Current [A]

$t_c \setminus t_e$	-20	-15	-10	-5	0	5	10
30	3.82	3.81	3.79	3.76	3.73	3.70	3.68
35	4.06	4.06	4.04	4.01	3.98	3.94	3.91
40	4.33	4.34	4.33	4.30	4.27	4.23	4.19
45	-	4.66	4.65	4.64	4.60	4.56	4.51
50	-	-	5.03	5.01	4.98	4.94	4.89
55	-	-	-	5.45	5.42	5.38	5.33
60	-	-	-	-	5.92	5.88	5.83
65	-	-	-	-	6.48	6.45	6.40

#### Mass flow [kg/s]

$t_c \setminus t_e$	-20	-15	-10	-5	0	5	10
30	85.28	105.65	128.79	155.01	184.63	217.96	255.30
35	84.06	104.25	127.26	153.40	182.98	216.31	253.71
40	82.68	102.68	125.55	151.59	181.11	214.43	251.87
45	-	100.89	123.60	149.52	178.98	212.28	249.73
50	-	-	121.38	147.18	176.55	209.81	247.27
55	-	-	-	144.51	173.78	206.99	244.44
60	-	-	-	-	170.65	203.78	241.21
65	-	-	-	-	167.10	200.15	237.54

# R.E.S.L

## Richmonds Earl Shilton Limited

Specialist Distributors of Compressors and Refrigeration Spares

**Model: ZR40K3E-TFD**

Capacity

### C.O.P. [W/W]

$t_c \setminus t_e$	-20	-15	-10	-5	0	5	10
30	2.22	2.80	3.48	4.29	5.25	6.36	7.65
35	1.88	2.37	2.95	3.63	4.44	5.38	6.47
40	1.58	2.00	2.49	3.07	3.75	4.56	5.49
45	-	1.68	2.09	2.59	3.17	3.85	4.64
50	-	-	1.75	2.17	2.66	3.24	3.92
55	-	-	-	1.81	2.23	2.72	3.30
60	-	-	-	-	1.85	2.27	2.76
65	-	-	-	-	1.53	1.88	2.29

### Application range

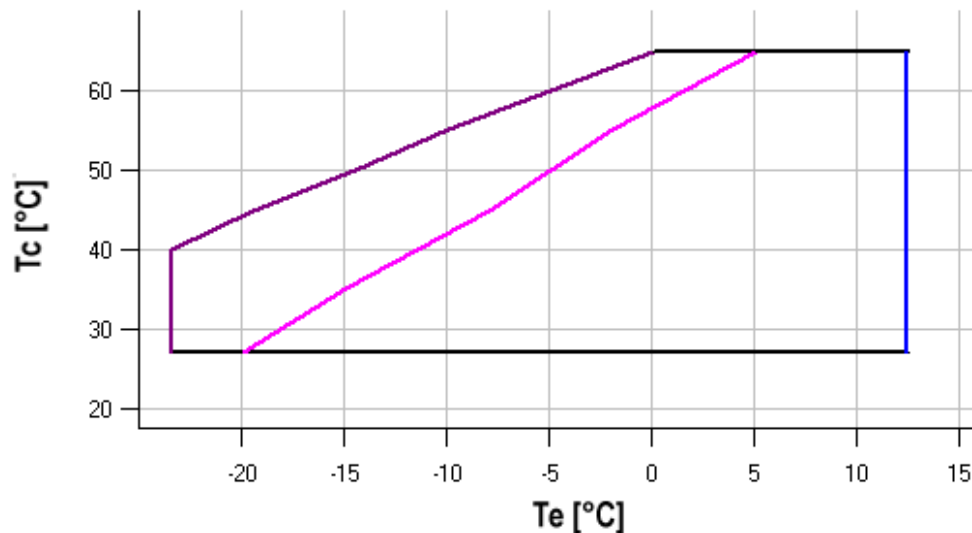

- Maximum evaporating temperature
- 25°C suction gas temperature
- 10K gas overheat

Operating conditions: 10K suction superheat, 0K subcooling

$t_c$  - Condensing temperature [°C]

$t_e$  - Evaporating temperature [°C]

# R.E.S.L

## Richmonds Earl Shilton Limited

Specialist Distributors of Compressors and Refrigeration Spares

**Model: ZR40K3E-TFD**

Capacity

R134a

### Cooling capacity [kW]

$t_c \setminus t_e$	-20	-15	-10	-5	0	5	10	15
30	2.22	2.92	3.76	4.73	5.84	7.09	8.51	-
35	2.01	2.69	3.50	4.44	5.52	6.75	8.14	-
40	1.83	2.47	3.25	4.16	5.21	6.41	7.76	9.27
45	-	2.27	3.01	3.89	4.90	6.06	7.37	8.85
50	-	2.08	2.78	3.61	4.58	5.70	6.97	8.40
55	-	-	2.55	3.33	4.26	5.33	6.55	7.93
60	-	-	-	3.04	3.91	4.93	6.10	7.43
65	-	-	-	2.74	3.55	4.51	5.62	6.89
70	-	-	-	-	3.16	4.06	5.10	6.31
75	-	-	-	-	2.74	3.57	4.55	5.68

### Power input [kW]

$t_c \setminus t_e$	-20	-15	-10	-5	0	5	10	15
30	1.20	1.17	1.15	1.15	1.14	1.14	1.12	-
35	1.40	1.36	1.34	1.33	1.32	1.32	1.31	-
40	1.61	1.56	1.53	1.51	1.50	1.50	1.49	1.48
45	-	1.77	1.73	1.71	1.69	1.69	1.68	1.67
50	-	2.01	1.95	1.92	1.90	1.89	1.89	1.88
55	-	-	2.21	2.16	2.13	2.12	2.11	2.11
60	-	-	-	2.44	2.40	2.38	2.37	2.37
65	-	-	-	2.76	2.71	2.68	2.67	2.66
70	-	-	-	-	3.07	3.03	3.01	3.00
75	-	-	-	-	3.48	3.44	3.41	3.39

# R.E.S.L

## Richmonds Earl Shilton Limited

Specialist Distributors of Compressors and Refrigeration Spares

### Model: ZR40K3E-TFD

Capacity

#### Current [A]

$t_c \setminus t_e$	-20	-15	-10	-5	0	5	10	15
30	3.19	3.15	3.10	3.05	3.01	2.98	2.99	-
35	3.44	3.41	3.35	3.30	3.24	3.19	3.16	-
40	3.66	3.63	3.59	3.53	3.46	3.39	3.34	3.30
45	-	3.85	3.81	3.75	3.68	3.61	3.53	3.47
50	-	4.06	4.04	4.00	3.93	3.85	3.76	3.68
55	-	-	4.30	4.27	4.21	4.13	4.04	3.94
60	-	-	-	4.59	4.55	4.47	4.38	4.28
65	-	-	-	4.98	4.96	4.90	4.81	4.71
70	-	-	-	-	5.45	5.41	5.34	5.24
75	-	-	-	-	6.06	6.04	5.99	5.90

#### Mass flow [kg/s]

$t_c \setminus t_e$	-20	-15	-10	-5	0	5	10	15
30	52.31	67.66	85.25	105.11	127.27	151.76	178.61	-
35	49.95	65.35	83.10	103.24	125.80	150.81	178.29	-
40	48.03	63.43	81.31	101.69	124.61	150.09	178.16	208.86
45	-	61.71	79.67	100.25	123.48	149.39	178.01	209.38
50	-	59.96	77.96	98.69	122.19	148.49	177.62	209.60
55	-	-	75.96	96.80	120.53	147.17	176.76	209.33
60	-	-	-	94.37	118.28	145.23	175.24	208.34
65	-	-	-	91.18	115.23	142.44	172.82	206.42
70	-	-	-	-	111.17	138.59	169.30	203.35
75	-	-	-	-	105.87	133.46	164.46	198.92

# R.E.S.L

## Richmonds Earl Shilton Limited

Specialist Distributors of Compressors and Refrigeration Spares

**Model: ZR40K3E-TFD**



Capacity

### C.O.P. [W/W]

$t_c \setminus t_e$	-20	-15	-10	-5	0	5	10	15
30	1.85	2.50	3.26	4.12	5.11	6.24	7.57	-
35	1.43	1.97	2.61	3.34	4.18	5.13	6.22	-
40	1.13	1.58	2.12	2.75	3.47	4.28	5.20	6.26
45	-	1.28	1.74	2.28	2.90	3.59	4.38	5.28
50	-	1.04	1.42	1.88	2.41	3.02	3.70	4.47
55	-	-	1.16	1.54	2.00	2.51	3.10	3.76
60	-	-	-	1.25	1.63	2.07	2.58	3.14
65	-	-	-	0.99	1.31	1.68	2.11	2.59
70	-	-	-	-	1.03	1.34	1.70	2.10
75	-	-	-	-	0.79	1.04	1.33	1.68

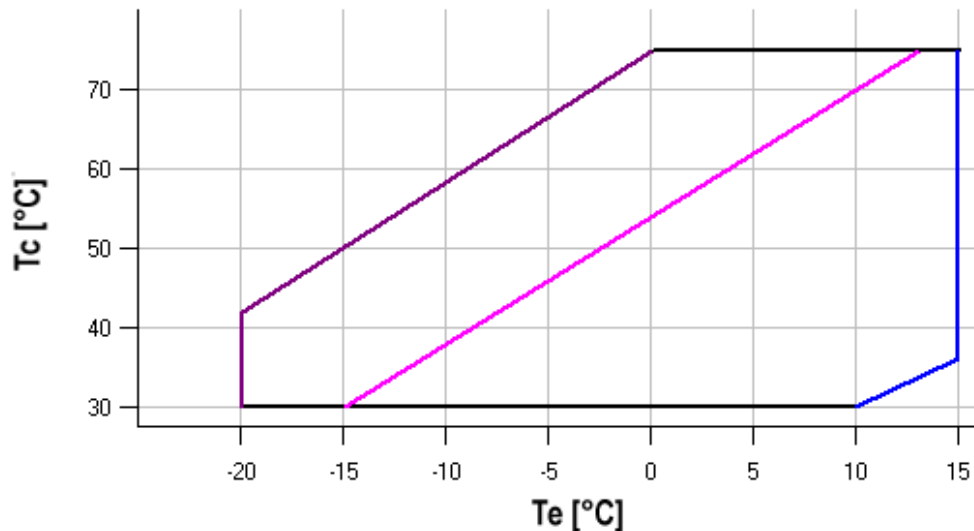
### Application range



-  Maximum evaporating temperature
-  25°C suction gas temperature
-  10K gas overheat

Operating conditions: 10K suction superheat, 0K subcooling

$t_c$  - Condensing temperature [°C]

$t_e$  - Evaporating temperature [°C]

# R.E.S.L

## Richmonds Earl Shilton Limited

Specialist Distributors of Compressors and Refrigeration Spares

### Model: ZR40K3E-TFD

Capacity

R407C

#### Cooling capacity [kW]

$t_c \setminus t_e$	-20	-15	-10	-5	0	5	10	15
30	3.42	4.33	5.47	6.84	8.43	10.26	12.32	14.62
35	3.17	4.06	5.17	6.50	8.05	9.84	11.85	-
40	2.92	3.77	4.84	6.12	7.62	9.35	11.30	-
45	-	3.48	4.49	5.71	7.15	8.81	10.69	-
50	-	-	4.13	5.28	6.65	8.22	10.01	-
55	-	-	-	4.83	6.11	7.59	9.28	-
60	-	-	-	-	5.55	6.92	8.51	-
65	-	-	-	-	-	6.23	7.69	-

#### Power input [kW]

$t_c \setminus t_e$	-20	-15	-10	-5	0	5	10	15
30	1.68	1.67	1.67	1.66	1.65	1.64	1.61	1.56
35	1.90	1.90	1.90	1.89	1.88	1.86	1.82	-
40	2.15	2.15	2.15	2.15	2.14	2.11	2.07	-
45	-	2.43	2.44	2.44	2.42	2.39	2.35	-
50	-	-	2.76	2.76	2.75	2.71	2.66	-
55	-	-	-	3.12	3.11	3.07	3.01	-
60	-	-	-	-	3.52	3.48	3.41	-
65	-	-	-	-	-	3.94	3.86	-



# R.E.S.L

## Richmonds Earl Shilton Limited

Specialist Distributors of Compressors and Refrigeration Spares

### Model: ZR40K3E-TFD

Capacity

#### Current [A]

$t_c \setminus t_e$	-20	-15	-10	-5	0	5	10	15
30	3.84	3.82	3.81	3.81	3.80	3.78	3.74	3.67
35	4.05	4.04	4.04	4.04	4.04	4.01	3.96	-
40	4.32	4.32	4.33	4.33	4.32	4.29	4.24	-
45	-	4.66	4.67	4.67	4.66	4.63	4.56	-
50	-	-	5.08	5.08	5.07	5.03	4.95	-
55	-	-	-	5.56	5.54	5.50	5.41	-
60	-	-	-	-	6.09	6.04	5.94	-
65	-	-	-	-	-	6.67	6.56	-

#### Mass flow [kg/s]

$t_c \setminus t_e$	-20	-15	-10	-5	0	5	10	15
30	71.91	89.73	111.50	137.17	166.67	199.91	236.83	277.37
35	69.93	88.03	110.19	136.33	166.37	200.25	237.90	-
40	67.86	86.07	108.41	134.82	165.22	199.54	237.72	-
45	-	83.86	106.20	132.68	163.25	197.82	236.33	-
50	-	-	103.58	129.95	160.48	195.11	233.76	-
55	-	-	-	126.66	156.97	191.45	230.05	-
60	-	-	-	-	152.73	186.88	225.22	-
65	-	-	-	-	-	181.42	219.33	-

# R.E.S.L

## Richmonds Earl Shilton Limited

Specialist Distributors of Compressors and Refrigeration Spares

**Model: ZR40K3E-TFD**

Capacity

### C.O.P. [W/W]

$t_c \setminus t_e$	-20	-15	-10	-5	0	5	10	15
30	2.03	2.59	3.28	4.11	5.10	6.27	7.67	9.37
35	1.67	2.14	2.72	3.43	4.28	5.29	6.50	-
40	1.36	1.75	2.25	2.85	3.57	4.43	5.46	-
45	-	1.43	1.84	2.35	2.95	3.68	4.56	-
50	-	-	1.50	1.91	2.42	3.03	3.77	-
55	-	-	-	1.55	1.96	2.47	3.08	-
60	-	-	-	-	1.58	1.99	2.49	-
65	-	-	-	-	-	1.58	1.99	-

### Application range

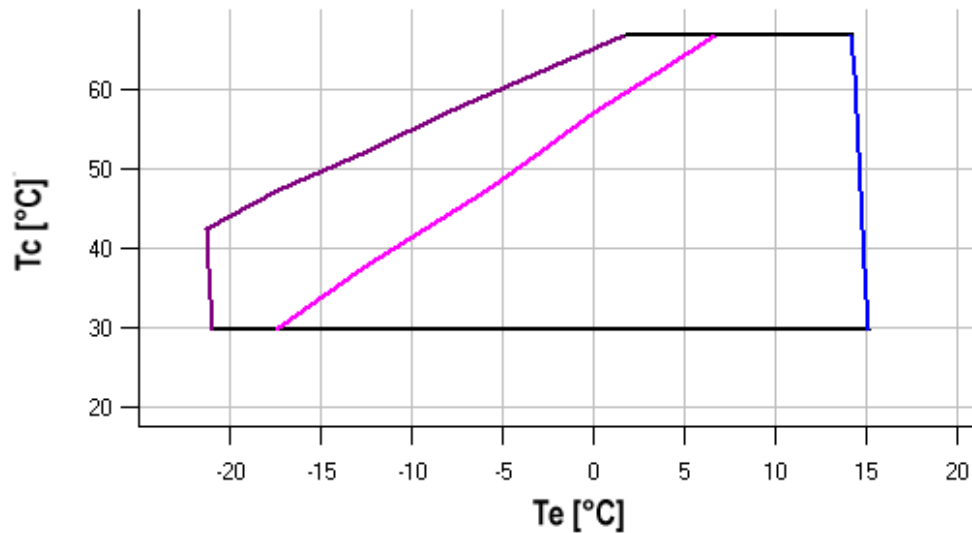

- Maximum evaporating temperature
- 25°C suction gas temperature
- 10K gas overheat

Operating conditions: 10K suction superheat, 0K subcooling

$t_c$  - Condensing temperature [°C]

$t_e$  - Evaporating temperature [°C]

# R.E.S.L

**Richmonds Earl Shilton Limited**

Specialist Distributors of Compressors and Refrigeration Spares

**Model: ZR40K3E-TFD**

Dimensions & image

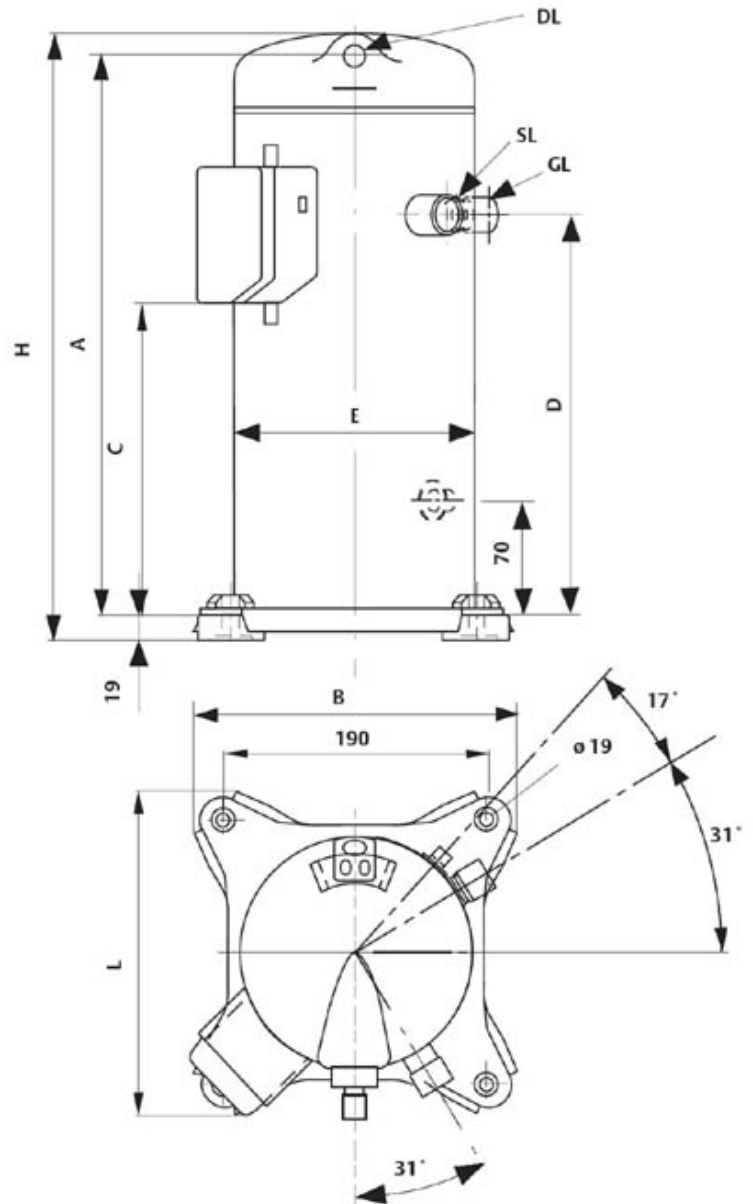

A	375 mm
B	240 mm
C	235 mm
D	277 mm
E	165 mm
H	419 mm
L	231 mm