

SC12G

Universal Compressor

R134a

220-240V 50Hz

Data Sheet (Replaces CD.44.P3.02)

General

Compressor	SC12G
Code number	104G8240
Code number	104G8243
Code number compressor with oil cooler	104G8250

Application

Application		LBP/HBP
Evaporating temperature range	°C	-35 to 15
Voltage range	V/Hz	LBP: 187 - 254 /50
		LBP: 198 - 254 /60
		HBP: 198 - 254 /50
Motor type		RSIR/CSIR
Max. ambient temperature	°C	43
Comp. cooling at ambient temp.	32°C	LBP: O/F ₁
		HBP: F ₂
	38°C	LBP: O/F ₁
		HBP: F ₂
43°C	LBP: O/F ₁	
	HBP: F ₂	

Design

Displacement	cm ³	12.87
Oil quantity	cm ³	550 (500 on comp. with oil cooler)
Maximum refrigerant charge	g	1300
Free gas vol. in compressor	cm ³	1510
Weight without electrical equipment	kg	12.6

Motor

Motor size	watt	315
LRA (rated after 4 sec. UL984) LST/HST	A	12.4/12.6
Cut-in current LST/HST	A	17.2/12.6
Resistance, main and start winding (25°C)	Ω	6.7/11.8
Approvals		EN 60335-2-34

Dimensions

		104G8250	104G8240	104G8243
Height	mm	A	209	
		B	203	
		B1	183	
		B2	100	
Suction connector	location/I.D. mm	C	8.2 ±0.09	8.2 ±0.09
Process connector	location/I.D. mm	D	6.2 ±0.09	6.5 ±0.09
Discharge connector	location/I.D. mm	E	6.2 ±0.09	6.5 ±0.09
Oil cooler	location/I.D. mm	F	6.2 ±0.09	
Compressors on a pallet	pcs.		80	

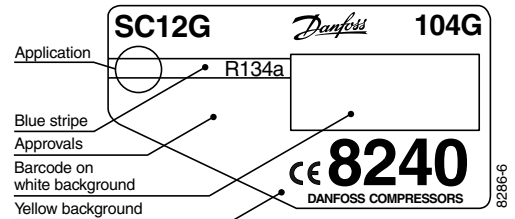

- S = Static cooling normally sufficient
- O = Oil cooling
- F₁ = Fan cooling 1.5 m/s
(compressor compartment temperature equal to ambient temperature)
- F₂ = Fan cooling 3.0 m/s necessary

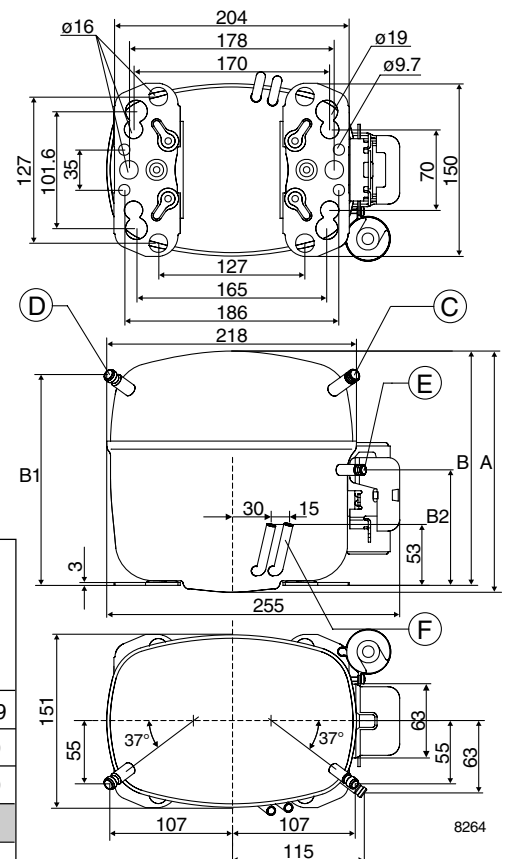

Capacity (EN 12900/CECOMAF)

watt

Evap. temp in °C	-35	-30	-25	-23.3	-20	-15	-10	-5	0	5	7.2	10	15
SC12G, 50Hz	64.6	113	175	199	252	348	464	603	768	960	1054	1182	1437
SC12G, 60Hz	74.2	131	203	232	294	406	542	704					

Capacity (ASHRAE)

watt

Evap. temp in °C	-35	-30	-25	-23.3	-20	-15	-10	-5	0	5	7.2	10	15
SC12G, 50Hz	79.6	140	216	246	312	430	574	746	951	1191	1308	1469	1790
SC12G, 60Hz	91.5	162	251	286	363	501	670	872					

Power consumption

watt

Evap. temp in °C	-35	-30	-25	-23.3	-20	-15	-10	-5	0	5	7.2	10	15
SC12G, 50Hz	148	187	227	241	268	311	355	400	446	493	514	541	589
SC12G, 60Hz	172	218	265	281	313	363	415	468					

Current consumption

A

Evap. temp in °C	-35	-30	-25	-23.3	-20	-15	-10	-5	0	5	7.2	10	15
SC12G, 50Hz	1.63	1.72	1.83	1.87	1.95	2.09	2.24	2.40	2.57	2.76	2.85	2.96	3.17
SC12G, 60Hz	1.79	1.89	2.01	2.06	2.15	2.30	2.46	2.64					

COP (EN 12900/CECOMAF)

W/W

Evap. temp in °C	-35	-30	-25	-23.3	-20	-15	-10	-5	0	5	7.2	10	15
SC12G, 50Hz	0.44	0.61	0.77	0.83	0.94	1.12	1.31	1.51	1.72	1.95	2.05	2.19	2.44
SC12G, 60Hz	0.43	0.60	0.77	0.83	0.94	1.12	1.31	1.51					

COP (ASHRAE)

W/W

Evap. temp in °C	-35	-30	-25	-23.3	-20	-15	-10	-5	0	5	7.2	10	15
SC12G, 50Hz	0.54	0.75	0.95	1.02	1.16	1.38	1.62	1.87	2.13	2.42	2.55	2.72	3.04
SC12G, 60Hz	0.53	0.74	0.95	1.02	1.16	1.38	1.61	1.86					

Test conditions	EN 12900/CECOMAF	ASHRAE
Condensing temperature	55°C	55°C
Ambient and suction gas temp.	32°C	32°C
Liquid temperature	55°C	32°C
50Hz: Fan cooling F_{21} , 220V		
60Hz: Fan cooling F_{22} , 220V		

Accessories

Devices		Fig.	SC12G
PTC starting device	6.3 mm spades	a1	103N0002
Starting relay		a2	117U6003
Cover		b	103N2009
Starting capacitor 80 µF		c	117U5017
Cord relief		d	103N1004
Mounting accessories			
Bolt joint for one compressor			118-1917
Bolt joint in quantities			118-1918
Snap-on in quantities			118-1919

