

# R.E.S.L

## Richmonds Earl Shilton Limited

Specialist Distributors of Compressors and Refrigeration Spares

### Model: MTZ28

#### Data

#### Technical data

Cylinder count:	1
Displacement [m <sup>3</sup> /h]:	8,36
Cylinder capacity [cm <sup>3</sup> ]:	48,1
RPM [min <sup>-1</sup> ]:	2900
Weight [kg]:	23
Oil charge [dm <sup>3</sup> ]:	1
Oil type:	160PZ
Crankcase heater type:	PTC 35 W
Maximum system test pressure low side / high side:	25 / 30
Maximum number of starts without softstart [1/h]:	12
Refrigerant charge limit [dm <sup>3</sup> ]:	3
Refrigerant:	R134a, 404A/R507, R407C
Sound power [dB]:	71
Sound power with accoustic hood [dB]:	64

#### Connections

	<u>milimeters</u>	<u>inches</u>
Suction Rotolock valve connection:		1"
Discharge Rotolock valve connection:		1"
Suction connection with supplied sleeve:		1/2"
Discharge connection with supplied sleeve:		3/8"

#### Approvals

CCC	+
CE	+
UL	+

# R.E.S.L

## Richmonds Earl Shilton Limited

Specialist Distributors of Compressors and Refrigeration Spares

### Model: MTZ28

R134a

Capacity

#### Cooling capacity [W]

$t_c \setminus t_e$	-15	-10	-5	0	5	10	15	20
35	1 649	2 260	3 034	3 997	5 172	6 583	8 255	10 212
40	1 491	2 065	2 793	3 701	4 812	6 150	7 740	9 605
45	1 353	1 884	2 560	3 407	4 448	5 707	7 209	8 978
50	1 236	1 718	2 337	3 117	4 082	5 257	6 665	8 330
55	1 142	1 569	2 125	2 832	3 715	4 799	6 108	7 665
60	-	1 439	1 925	2 553	3 349	4 337	5 539	6 982
65	-	-	-	2 283	2 985	3 870	4 961	6 283
70	-	-	-	-	-	3 401	4 375	5 571
75	-	-	-	-	-	-	3 782	4 845

#### Power input [W]

$t_c \setminus t_e$	-15	-10	-5	0	5	10	15	20
35	850	942	1 030	1 112	1 185	1 246	1 293	1 323
40	883	983	1 081	1 174	1 260	1 336	1 400	1 449
45	911	1 020	1 129	1 235	1 335	1 428	1 510	1 579
50	935	1 054	1 174	1 294	1 410	1 520	1 622	1 712
55	951	1 081	1 215	1 350	1 483	1 612	1 734	1 847
60	-	1 102	1 251	1 402	1 553	1 702	1 846	1 982
65	-	-	-	1 448	1 619	1 789	1 956	2 117
70	-	-	-	-	-	1 871	2 063	2 250
75	-	-	-	-	-	-	2 165	2 380

#### Current [A]

$t_c \setminus t_e$	-15	-10	-5	0	5	10	15	20
35	2.70	2.76	2.82	2.88	2.94	2.99	3.04	3.08
40	2.73	2.80	2.87	2.95	3.02	3.09	3.16	3.23
45	2.75	2.83	2.92	3.01	3.10	3.19	3.28	3.38
50	2.76	2.85	2.96	3.06	3.18	3.29	3.41	3.53
55	2.76	2.87	2.99	3.12	3.25	3.39	3.53	3.68
60	-	2.88	3.02	3.17	3.32	3.48	3.66	3.83
65	-	-	-	3.21	3.39	3.58	3.78	3.99
70	-	-	-	-	-	3.67	3.90	4.14
75	-	-	-	-	-	-	4.02	4.30

# R.E.S.L

## Richmonds Earl Shilton Limited

Specialist Distributors of Compressors and Refrigeration Spares

### Mass flow [kg/s]

### Capacity

$t_c \setminus t_e$	-15	-10	-5	0	5	10	15	20
35	36.82	49.43	64.99	83.88	106.50	133.22	164.44	200.53
40	34.72	47.12	62.44	81.07	103.40	129.80	160.68	196.40
45	33.02	45.02	59.92	78.11	99.96	125.87	156.21	191.38
50	31.77	43.20	57.50	75.05	96.25	121.47	151.11	185.54
55	31.05	41.72	55.23	71.97	92.33	116.69	145.43	178.94
60	-	40.63	53.18	68.92	88.26	111.57	139.24	171.65
65	-	-	-	65.98	84.11	106.18	132.59	163.72
70	-	-	-	-	-	100.59	125.56	155.22
75	-	-	-	-	-	-	118.20	146.20

### C.O.P. [W/W]

$t_c \setminus t_e$	-15	-10	-5	0	5	10	15	20
35	1.94	2.40	2.94	3.59	4.36	5.28	6.38	7.72
40	1.69	2.10	2.58	3.15	3.82	4.60	5.53	6.63
45	1.48	1.85	2.27	2.76	3.33	4.00	4.77	5.69
50	1.32	1.63	1.99	2.41	2.89	3.46	4.11	4.87
55	1.20	1.45	1.75	2.10	2.50	2.98	3.52	4.15
60	-	1.31	1.54	1.82	2.16	2.55	3.00	3.52
65	-	-	-	1.58	1.84	2.16	2.54	2.97
70	-	-	-	-	-	1.82	2.12	2.48
75	-	-	-	-	-	-	1.75	2.04

Operating conditions: suction superheat: 11.1 K, subcooling: 8.3 K

$t_c$  - Condensing temperature [°C]

$t_e$  - Evaporating temperature [°C]

### Application range

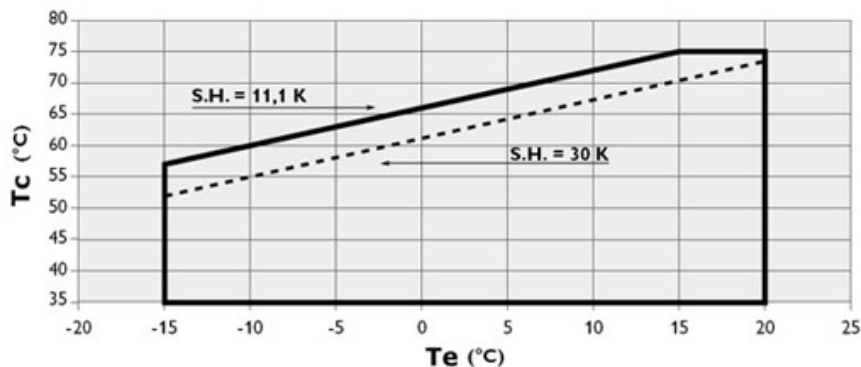

# R.E.S.L

## Richmonds Earl Shilton Limited

Specialist Distributors of Compressors and Refrigeration Spares

K4U4A/K3U7

### Cooling capacity [W]

$t_c \setminus t_e$	-30	-25	-20	-15	-10	-5	0	5	10
30	1 417	2 050	2 825	3 757	4 866	6 168	7 683	9 428	11 421
35	1 182	1 769	2 485	3 348	4 375	5 585	6 995	8 624	10 488
40	963	1 503	2 159	2 951	3 896	5 011	6 315	7 826	9 562
45	759	1 250	1 846	2 566	3 427	4 447	5 644	7 037	8 642
50	570	1 012	1 546	2 193	2 969	3 892	4 982	6 254	7 728
55	-	787	1 260	1 832	2 522	3 348	4 328	5 480	6 821
60	-	578	986	1 483	2 086	2 813	3 682	4 712	5 920

### Power input [W]

$t_c \setminus t_e$	-30	-25	-20	-15	-10	-5	0	5	10
30	1 106	1 291	1 462	1 614	1 747	1 856	1 940	1 996	2 020
35	1 094	1 298	1 488	1 663	1 818	1 952	2 062	2 144	2 197
40	1 076	1 300	1 511	1 708	1 888	2 047	2 184	2 295	2 378
45	1 050	1 295	1 529	1 750	1 955	2 141	2 306	2 446	2 560
50	1 016	1 283	1 541	1 787	2 019	2 232	2 426	2 598	2 743
55	-	1 263	1 546	1 818	2 077	2 320	2 545	2 748	2 927
60	-	1 234	1 543	1 842	2 130	2 403	2 659	2 895	3 109

### Current [A]

$t_c \setminus t_e$	-30	-25	-20	-15	-10	-5	0	5	10
30	3.07	3.24	3.42	3.60	3.77	3.92	4.05	4.13	4.17
35	3.08	3.26	3.46	3.65	3.84	4.02	4.16	4.27	4.33
40	3.07	3.28	3.50	3.72	3.94	4.14	4.31	4.45	4.54
45	3.04	3.28	3.53	3.79	4.04	4.28	4.49	4.67	4.80
50	2.97	3.25	3.54	3.84	4.14	4.42	4.68	4.91	5.09
55	-	3.18	3.52	3.87	4.22	4.56	4.87	5.16	5.39
60	-	3.05	3.46	3.87	4.28	4.68	5.05	5.40	5.70

# R.E.S.L

## Richmonds Earl Shilton Limited

Specialist Distributors of Compressors and Refrigeration Spares

### Model: MTZ28

Capacity

#### Mass flow [kg/s]

$t_c \setminus t_e$	-30	-25	-20	-15	-10	-5	0	5	10
30	44.50	63.12	84.76	109.84	138.74	171.85	209.57	252.28	300.38
35	40.01	58.43	79.81	104.56	133.06	165.71	202.90	245.02	292.45
40	35.37	53.60	74.74	99.17	127.30	159.50	196.17	237.71	284.51
45	30.56	48.63	69.53	93.67	121.43	153.20	189.38	230.35	276.52
50	25.56	43.48	64.17	88.03	115.44	146.80	182.49	222.92	268.47
55	-	38.15	58.64	82.23	109.31	140.27	175.50	215.40	260.35
60	-	32.61	52.92	76.26	103.02	133.60	168.38	207.76	252.13

#### C.O.P. [W/W]

$t_c \setminus t_e$	-30	-25	-20	-15	-10	-5	0	5	10
30	1.28	1.59	1.93	2.33	2.79	3.32	3.96	4.72	5.65
35	1.08	1.36	1.67	2.01	2.41	2.86	3.39	4.02	4.77
40	0.90	1.16	1.43	1.73	2.06	2.45	2.89	3.41	4.02
45	0.72	0.97	1.21	1.47	1.75	2.08	2.45	2.88	3.38
50	0.56	0.79	1.00	1.23	1.47	1.74	2.05	2.41	2.82
55	-	0.62	0.81	1.01	1.21	1.44	1.70	1.99	2.33
60	-	0.47	0.64	0.80	0.98	1.17	1.38	1.63	1.90

Operating conditions: suction superheat: 10 K, subcooling: 0 K

$t_c$  - Condensing temperature [°C]

$t_e$  - Evaporating temperature [°C]

#### Application range

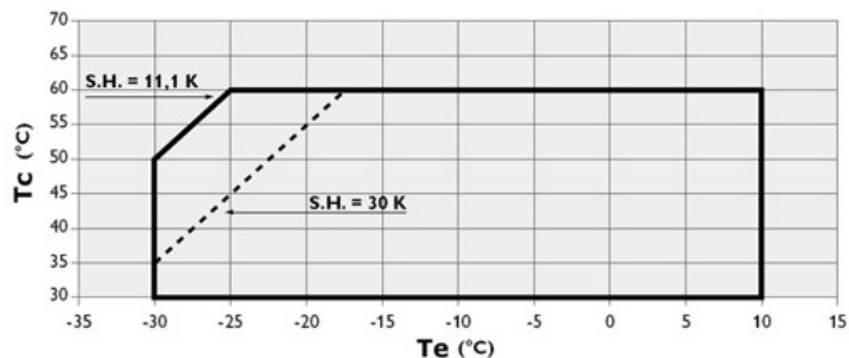

# R.E.S.L

## Richmonds Earl Shilton Limited

Specialist Distributors of Compressors and Refrigeration Spares

### Model: MTZ28

Capacity

R407C

#### Cooling capacity [W]

$t_c \setminus t_e$	-15	-10	-5	0	5	10	15
35	2 544	3 518	4 673	6 032	7 616	9 449	11 550
40	2 262	3 187	4 278	5 558	7 049	8 772	10 751
45	1 975	2 849	3 875	5 075	6 470	8 084	9 938
50	-	2 509	3 467	4 585	5 885	7 387	9 115
55	-	-	3 058	4 093	5 294	6 684	8 284
60	-	-	-	3 601	4 703	5 978	7 450
65	-	-	-	3 112	4 113	5 273	6 614

#### Power input [W]

$t_c \setminus t_e$	-15	-10	-5	0	5	10	15
35	1 262	1 422	1 555	1 660	1 735	1 778	1 789
40	1 289	1 480	1 644	1 779	1 883	1 956	1 995
45	1 297	1 523	1 721	1 890	2 028	2 133	2 206
50	-	1 548	1 784	1 990	2 165	2 308	2 417
55	-	-	1 830	2 077	2 294	2 477	2 626
60	-	-	-	2 148	2 409	2 636	2 829
65	-	-	-	2 199	2 508	2 784	3 025

#### Current [A]

$t_c \setminus t_e$	-15	-10	-5	0	5	10	15
35	3.22	3.38	3.53	3.65	3.74	3.82	3.88
40	3.25	3.46	3.64	3.79	3.92	4.02	4.10
45	3.25	3.51	3.74	3.94	4.11	4.25	4.36
50	-	3.54	3.83	4.08	4.30	4.48	4.64
55	-	-	3.89	4.21	4.49	4.73	4.94
60	-	-	-	4.31	4.66	4.97	5.24
65	-	-	-	4.39	4.82	5.20	5.55

# R.E.S.L

## Richmonds Earl Shilton Limited

Specialist Distributors of Compressors and Refrigeration Spares

### Model: MTZ28

Capacity

#### Mass flow [kg/s]

$t_c \setminus t_e$	-15	-10	-5	0	5	10	15
35	55.21	75.10	98.11	124.63	155.00	189.61	228.82
40	51.61	71.44	94.27	120.47	150.40	184.44	222.94
45	47.62	67.37	89.98	115.84	145.29	178.72	216.49
50	-	62.88	85.25	110.72	139.67	172.46	209.46
55	-	-	80.07	105.14	133.54	165.66	201.86
60	-	-	-	99.08	126.91	158.33	193.69
65	-	-	-	92.55	119.78	150.46	184.96

#### C.O.P. [W/W]

$t_c \setminus t_e$	-15	-10	-5	0	5	10	15
35	2.02	2.47	3.00	3.63	4.39	5.31	6.46
40	1.76	2.15	2.60	3.12	3.74	4.49	5.39
45	1.52	1.87	2.25	2.69	3.19	3.79	4.51
50	-	1.62	1.94	2.30	2.72	3.20	3.77
55	-	-	1.67	1.97	2.31	2.70	3.16
60	-	-	-	1.68	1.95	2.27	2.63
65	-	-	-	1.42	1.64	1.89	2.19

Operating conditions: suction superheat: 10 K, subcooling: 0 K

$t_c$  - Condensing temperature [°C]

$t_e$  - Evaporating temperature [°C]

#### Application range

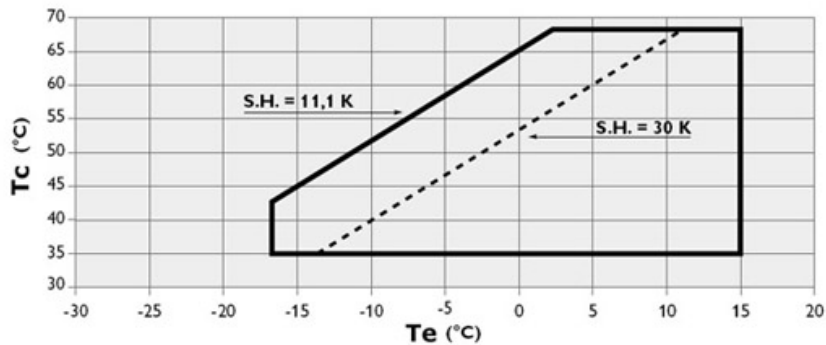



# R.E.S.L

**Richmonds Earl Shilton Limited**

**Specialist Distributors of Compressors and Refrigeration Spares**

**Model: MTZ28**

**Dimensions**

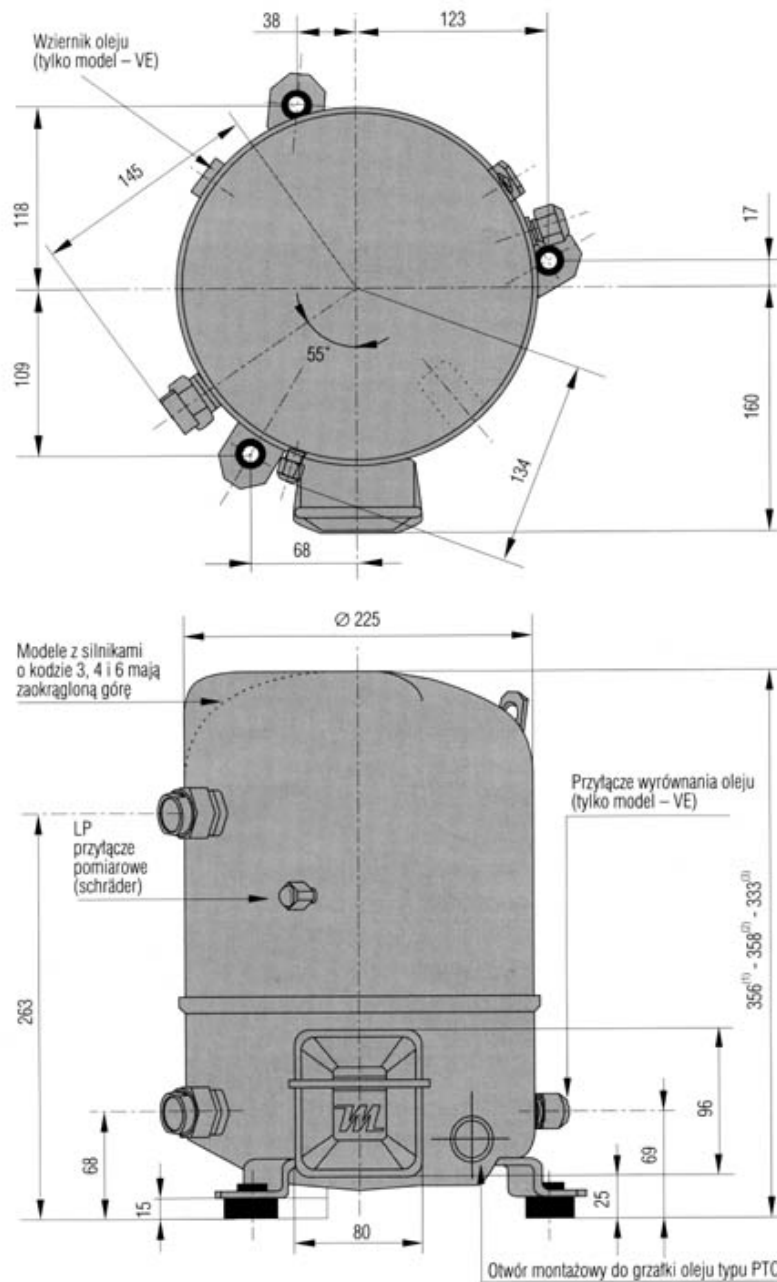



# R.E.S.L

**Richmonds Earl Shilton Limited**

**Specialist Distributors of Compressors and Refrigeration Spares**

**Model: MTZ28**

**Image**



# R.E.S.L

## Richmonds Earl Shilton Limited

Specialist Distributors of Compressors and Refrigeration Spares

**Model: MTZ28**

Electrical

### Single phase power supply

#### Electrical data

Motor voltage code:	1	5
Starting current [A]:	81	55
Maximum Continuous Current (MCC) [A]:	25	16
Winding resistance (between phases) (run/start) [ $\Omega$ ):	0,74/1,85	1,16/3,24
Main condenser (A) (PSC/CSR) [ $\mu\text{F}$ ):		20
Main condenser (C) (PSC/CSR) [ $\mu\text{F}$ ):		10
Starting condenser (B) (CSR) [ $\mu\text{F}$ ):		100
Starting relay (CSR):		3ARR3J4A4

### PSC starting with additional winding

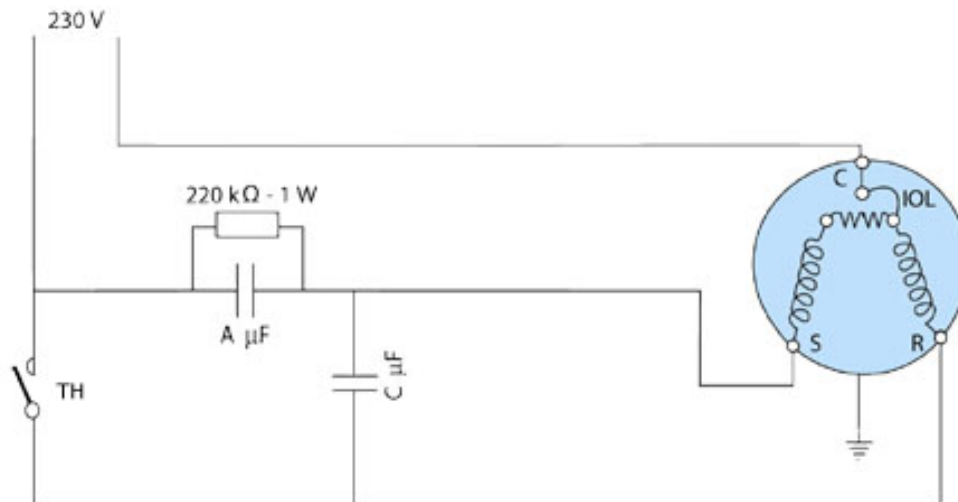

IOL: inner motor protection (klixon)  
A, C: main condensers  
C: starting condenser / S: common  
TH: thermostat  
SR: movement transmitter

# R.E.S.L

**Richmonds Earl Shilton Limited**

**Specialist Distributors of Compressors and Refrigeration Spares**

**Model: MTZ28**

**Electrical**

## CSR starting with additional winding

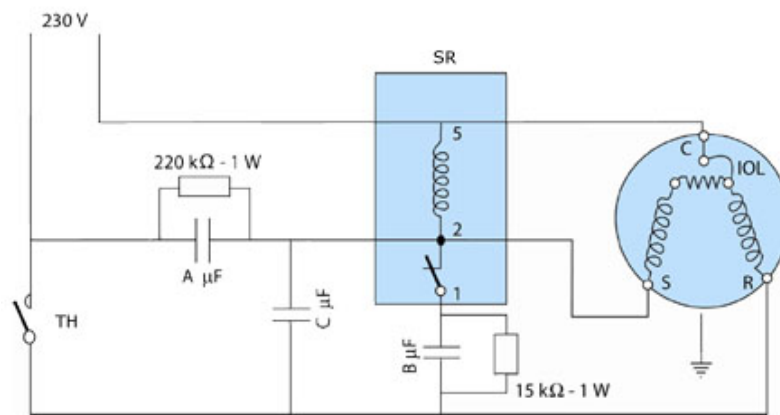

IOL: inner motor protection (klixon)

A, C: main condensers

B: starting condenser

C: common / S: additional starting winding

TH: thermostat

SR: movement transmitter

## CSR starting without additional winding

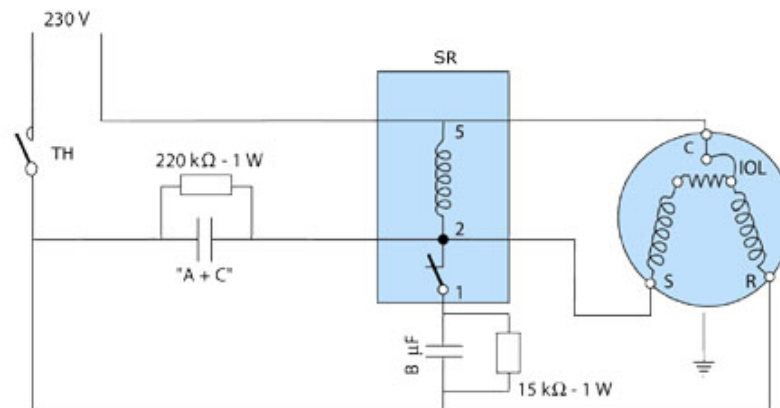

IOL: inner motor protection (klixon)

A, C: main condensers

B: starting condenser

C: common / S: additional starting winding

TH: thermostat

SR: movement transmitter

condensers A and C are replaced by one condenser of capacity A + C

# R.E.S.L

**Richmonds Earl Shilton Limited**

**Specialist Distributors of Compressors and Refrigeration Spares**

## **Model: MTZ28**

**Electrical**

### **Three-phase power supply**

#### **Electrical data**

Motor voltage code:	3	4	6	7	9
Starting current [A]:	57	23	41	20	32
Maximum Continuous Current (MCC) [A]:	16	7,5	41	6	8,5
Winding resistance (between phases) [ $\Omega$ ]:	1,37	7,11	2,3	10,6	4,8

### **Connection diagram for systems without refrigerant suction**

TH: Thermostat

180 s: Optional short cycle timer (3min) 5 pts

KA: Control relay

LLSV: Liquid Solenoid valve

KM: Compressor contactor

KS: Safety lock out relay

BP: Low pressure switch

HP: High pressure switch

Q1: Fused disconnect

F1: Fuses

F2: External overload protection

M: Compressor's engine

thM: Motor safety thermostat

DGT: Discharge gas thermostat

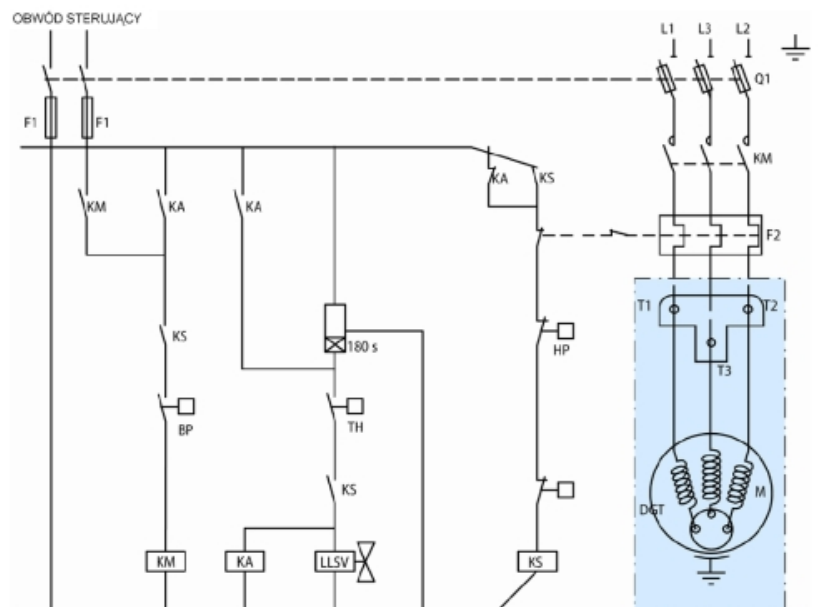

# R.E.S.L

**Richmonds Earl Shilton Limited**

**Specialist Distributors of Compressors and Refrigeration Spares**

**Model: MTZ28**

**Electrical**

## Connection diagram for systems with refrigerant suction

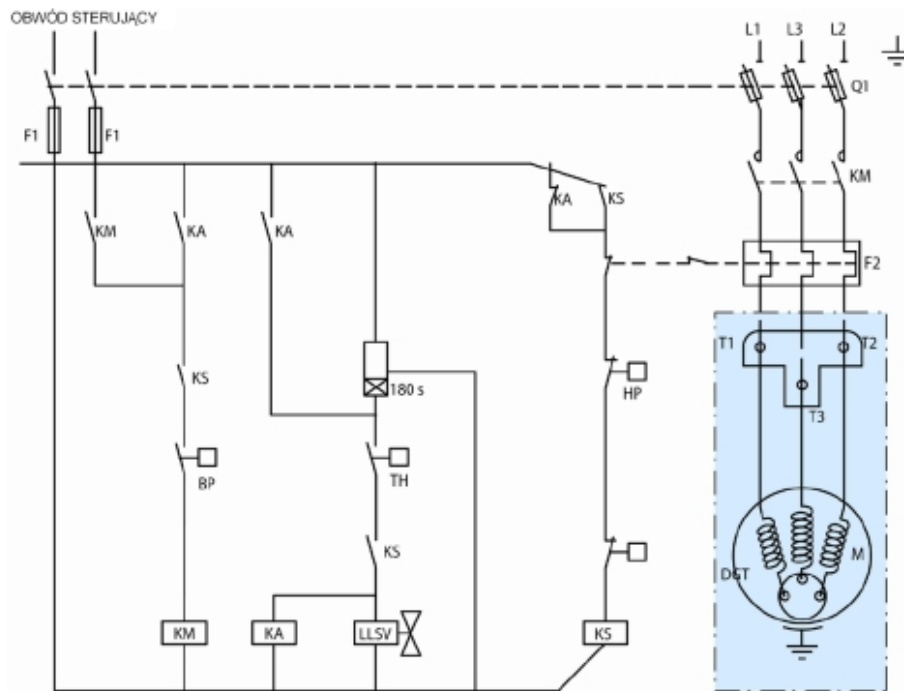

TH: Thermostat

180 s: Optional short cycle timer (3min) 5 pts

KA: Control relay

LLSV: Liquid Solenoid valve

KM: Compressor contactor

KS: Safety lock out relay

BP: Low pressure switch

HP: High pressure switch

Q1: Fused disconnect

F1: Fuses

F2: External overload protection

M: Compressor's engine

thM: Motor safety thermostat

DGT: Discharge gas thermostat

# R.E.S.L

**Richmonds Earl Shilton Limited**

**Specialist Distributors of Compressors and Refrigeration Spares**

**Model: MTZ28**

**Equipment**

## **Equipment**

- ▶ crankcase heater - PTC 35 W
- ▶ belt type heater - crankcase heater 55W, 230V
- ▶ Rotolock valves
  - suction: Rotolock valve connection 1", connection with supplied sleeve 1/2"
  - discharge: Rotolock valve connection 1", connection with supplied sleeve 3/8"
- ▶ soft-start kit - electronic softstart MCI 15C
- ▶ accoustic hood - acoustic shield of Danfoss catalogue number 7755001