

# R.E.S.L

## Richmonds Earl Shilton Limited

Specialist Distributors of Compressors and Refrigeration Spares

### Model: MTZ50

#### Data

#### Technical data

Cylinder count:	2
Displacement [m <sup>3</sup> /h]:	14,9
Cylinder capacity [cm <sup>3</sup> ]:	85,6
RPM [min <sup>-1</sup> ]:	2900
Weight [kg]:	35
Oil charge [dm <sup>3</sup> ]:	2
Oil type:	160PZ
Crankcase heater type:	PTC 35 W
Maximum system test pressure low side / high side:	25 / 30
Maximum number of starts without softstart [1/h]:	12
Refrigerant charge limit [dm <sup>3</sup> ]:	5
Refrigerant:	R134a, 404A/R507, R407C
Sound power [dB]:	83
Sound power with acoustic hood [dB]:	76

#### Connections

	<u>millimeters</u>	<u>inches</u>
Suction Rotolock valve connection:		1 3/4"
Discharge Rotolock valve connection:		1 1/4"
Suction connection with supplied sleeve:		7/8"
Discharge connection with supplied sleeve:		3/4"

#### Approvals

CCC	+
CE	+
UL	+

# R.E.S.L

## Richmonds Earl Shilton Limited

Specialist Distributors of Compressors and Refrigeration Spares

R134a

**Model: MTZ50**

Capacity

### Cooling capacity [W]

$t_c \setminus t_e$	-15	-10	-5	0	5	10	15	20
35	3 348	4 552	6 039	7 848	10 016	12 582	15 584	19 060
40	2 967	4 108	5 517	7 231	9 290	11 730	14 592	17 912
45	2 632	3 699	5 019	6 629	8 568	10 873	13 584	16 739
50	2 341	3 325	4 546	6 042	7 851	10 012	12 562	15 541
55	2 095	2 986	4 098	5 469	7 139	9 144	11 524	14 317
60	-	2 682	3 675	4 912	6 432	8 272	10 472	13 069
65	-	-	-	4 369	5 730	7 395	9 404	11 795
70	-	-	-	-	-	6 513	8 322	10 497
75	-	-	-	-	-	-	7 225	9 174

### Power input [W]

$t_c \setminus t_e$	-15	-10	-5	0	5	10	15	20
35	1 719	1 898	2 059	2 197	2 302	2 369	2 390	2 357
40	1 763	1 957	2 139	2 299	2 432	2 530	2 586	2 592
45	1 794	2 007	2 210	2 397	2 560	2 692	2 785	2 832
50	1 810	2 044	2 272	2 487	2 683	2 851	2 984	3 076
55	1 810	2 067	2 322	2 569	2 799	3 006	3 182	3 320
60	-	2 074	2 359	2 639	2 907	3 156	3 377	3 564
65	-	-	-	2 698	3 005	3 298	3 567	3 805
70	-	-	-	-	-	3 430	3 750	4 043
75	-	-	-	-	-	-	3 924	4 274

### Current [A]

$t_c \setminus t_e$	-15	-10	-5	0	5	10	15	20
35	4.57	4.69	4.81	4.92	5.01	5.08	5.12	5.14
40	4.60	4.74	4.88	5.01	5.12	5.22	5.30	5.35
45	4.61	4.77	4.93	5.08	5.23	5.36	5.47	5.57
50	4.61	4.79	4.97	5.15	5.33	5.49	5.65	5.78
55	4.59	4.80	5.00	5.21	5.42	5.62	5.82	6.00
60	-	4.78	5.02	5.26	5.51	5.75	5.99	6.21
65	-	-	-	5.30	5.58	5.87	6.15	6.43
70	-	-	-	-	-	5.98	6.31	6.64
75	-	-	-	-	-	-	6.47	6.85

# R.E.S.L

## Richmonds Earl Shilton Limited

Specialist Distributors of Compressors and Refrigeration Spares

### Model: MTZ50

#### Mass flow [kg/s]

#### Capacity

$t_c \setminus t_e$	-15	-10	-5	0	5	10	15	20
35	74.59	99.39	129.19	164.58	206.18	254.56	310.32	374.07
40	69.18	93.81	123.37	158.47	199.70	247.66	302.93	366.13
45	64.30	88.47	117.52	152.03	192.61	239.85	294.36	356.72
50	60.15	83.57	111.81	145.44	185.09	231.33	284.77	346.01
55	56.91	79.29	106.43	138.91	177.33	222.28	274.38	334.20
60	-	75.82	101.58	132.61	169.52	212.90	263.35	321.47
65	-	-	-	126.73	161.84	203.36	251.89	308.02
70	-	-	-	-	-	193.86	240.18	294.03
75	-	-	-	-	-	-	228.40	279.70

#### C.O.P. [W/W]

$t_c \setminus t_e$	-15	-10	-5	0	5	10	15	20
35	1.95	2.40	2.93	3.57	4.35	5.31	6.52	8.09
40	1.68	2.10	2.58	3.14	3.82	4.64	5.64	6.91
45	1.47	1.84	2.27	2.77	3.35	4.04	4.88	5.91
50	1.29	1.63	2.00	2.43	2.93	3.51	4.21	5.05
55	1.16	1.44	1.76	2.13	2.55	3.04	3.62	4.31
60	-	1.29	1.56	1.86	2.21	2.62	3.10	3.67
65	-	-	-	1.62	1.91	2.24	2.64	3.10
70	-	-	-	-	-	1.90	2.22	2.60
75	-	-	-	-	-	-	1.84	2.15

Operating conditions: suction superheat: 11.1 K, subcooling: 8.3 K

$t_c$  - Condensing temperature [°C]

$t_e$  - Evaporating temperature [°C]

#### Application range

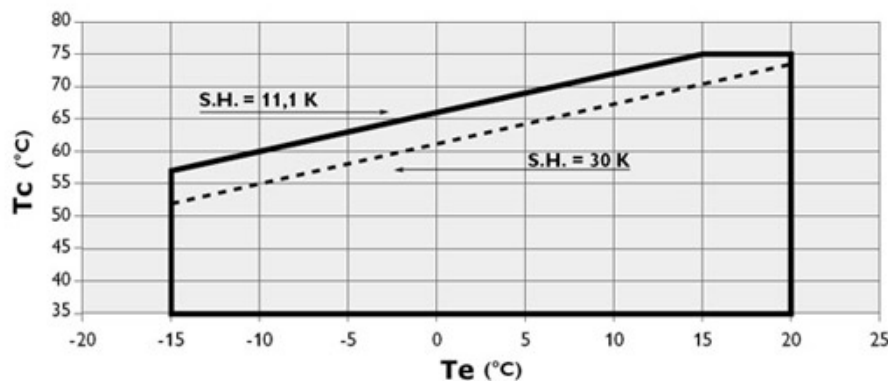

# R.E.S.L

## Richmonds Earl Shilton Limited

Specialist Distributors of Compressors and Refrigeration Spares

### Model: MTZ50

R404A/R507

Capacity

### Cooling capacity [W]

$t_c \setminus t_e$	-30	-25	-20	-15	-10	-5	0	5	10
30	3 523	4 582	5 951	7 676	9 807	12 389	15 471	19 100	23 323
35	2 899	3 917	5 217	6 847	8 854	11 286	14 190	17 614	21 604
40	2 371	3 328	4 541	6 056	7 921	10 183	12 891	16 090	19 830
45	1 943	2 821	3 927	5 308	7 012	9 086	11 578	14 534	18 003
50	1 619	2 399	3 380	4 608	6 132	7 999	10 255	12 950	16 129
55	-	2 068	2 904	3 961	5 285	6 925	8 928	11 341	14 212
60	-	1 831	2 504	3 370	4 476	5 870	7 601	9 714	12 257

### Power input [W]

$t_c \setminus t_e$	-30	-25	-20	-15	-10	-5	0	5	10
30	2 108	2 404	2 686	2 943	3 163	3 337	3 453	3 500	3 469
35	2 199	2 505	2 802	3 081	3 331	3 539	3 697	3 792	3 814
40	2 253	2 573	2 891	3 197	3 479	3 727	3 930	4 078	4 159
45	2 271	2 609	2 952	3 289	3 609	3 901	4 154	4 358	4 502
50	2 253	2 614	2 986	3 358	3 720	4 061	4 369	4 634	4 845
55	-	2 588	2 994	3 406	3 814	4 207	4 575	4 905	5 188
60	-	2 532	2 976	3 433	3 892	4 342	4 772	5 173	5 532

### Current [A]

$t_c \setminus t_e$	-30	-25	-20	-15	-10	-5	0	5	10
30	4.80	5.13	5.44	5.73	5.97	6.16	6.29	6.34	6.31
35	4.90	5.24	5.58	5.89	6.17	6.41	6.60	6.72	6.76
40	4.95	5.32	5.68	6.03	6.36	6.66	6.91	7.10	7.22
45	4.97	5.36	5.75	6.15	6.53	6.89	7.21	7.48	7.68
50	4.94	5.36	5.79	6.24	6.68	7.10	7.50	7.85	8.15
55	-	5.31	5.80	6.30	6.80	7.30	7.77	8.22	8.62
60	-	5.22	5.76	6.32	6.89	7.47	8.03	8.58	9.09

# R.E.S.L

## Richmonds Earl Shilton Limited

Specialist Distributors of Compressors and Refrigeration Spares

### Mass flow [kg/s]

Capacity

$t_c \setminus t_e$	-30	-25	-20	-15	-10	-5	0	5	10
30	97.23	126.02	160.96	202.95	252.88	311.63	380.09	459.14	549.66
35	85.58	114.54	149.68	191.87	242.01	300.97	369.65	448.92	539.68
40	76.17	104.68	139.37	181.13	230.83	289.37	357.63	436.49	526.85
45	69.25	96.68	130.28	170.96	219.60	277.07	344.28	422.09	511.41
50	65.07	90.76	122.65	161.61	208.54	264.32	329.83	405.96	493.60
55	-	87.18	116.71	153.33	197.91	251.35	314.53	388.34	473.66
60	-	86.18	112.71	146.34	187.94	238.40	298.61	369.46	451.83

### C.O.P. [W/W]

$t_c \setminus t_e$	-30	-25	-20	-15	-10	-5	0	5	10
30	1.67	1.91	2.22	2.61	3.10	3.71	4.48	5.46	6.72
35	1.32	1.56	1.86	2.22	2.66	3.19	3.84	4.64	5.66
40	1.05	1.29	1.57	1.89	2.28	2.73	3.28	3.95	4.77
45	0.86	1.08	1.33	1.61	1.94	2.33	2.79	3.33	4.00
50	0.72	0.92	1.13	1.37	1.65	1.97	2.35	2.79	3.33
55	-	0.80	0.97	1.16	1.39	1.65	1.95	2.31	2.74
60	-	0.72	0.84	0.98	1.15	1.35	1.59	1.88	2.22

Operating conditions: suction superheat: 11.1 K, subcooling: 8.3 K

$t_c$  - Condensing temperature [°C]

$t_e$  - Evaporating temperature [°C]

### Application range

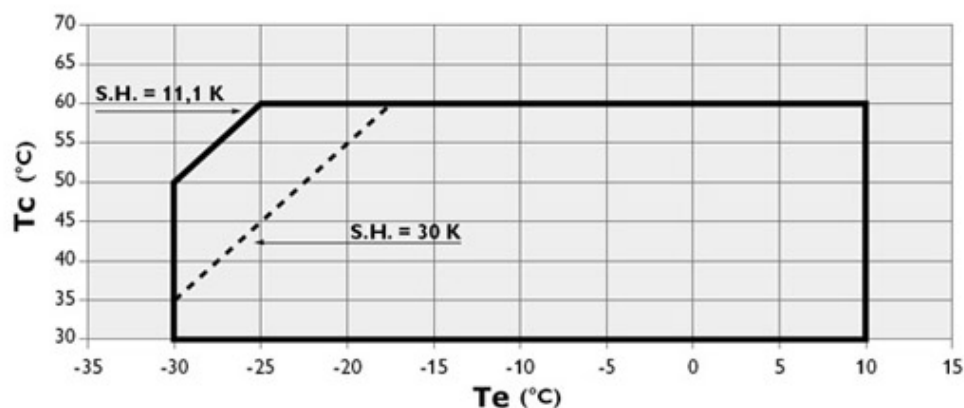

# R.E.S.L

## Richmonds Earl Shilton Limited

Specialist Distributors of Compressors and Refrigeration Spares

R407C

**Model: MTZ50**

Capacity

### Cooling capacity [W]

$t_c \setminus t_e$	-15	-10	-5	0	5	10	15
35	4 936	6 692	8 805	11 314	14 258	17 677	21 611
40	4 398	6 068	8 074	10 455	13 249	16 497	20 238
45	3 876	5 446	7 330	9 568	12 198	15 260	18 793
50	-	4 836	6 583	8 663	11 113	13 975	17 286
55	-	-	5 843	7 750	10 007	12 653	15 727
60	-	-	-	6 839	8 887	11 303	14 126
65	-	-	-	5 941	7 766	9 937	12 494

### Power input [W]

$t_c \setminus t_e$	-15	-10	-5	0	5	10	15
35	2 281	2 543	2 779	2 978	3 131	3 229	3 262
40	2 359	2 647	2 916	3 154	3 353	3 503	3 595
45	2 417	2 736	3 041	3 323	3 573	3 780	3 935
50	-	2 805	3 152	3 482	3 787	4 055	4 279
55	-	-	3 244	3 627	3 991	4 325	4 621
60	-	-	-	3 753	4 181	4 586	4 959
65	-	-	-	3 858	4 354	4 834	5 288

### Current [A]

$t_c \setminus t_e$	-15	-10	-5	0	5	10	15
35	5.12	5.41	5.66	5.88	6.06	6.19	6.26
40	5.20	5.52	5.82	6.10	6.34	6.55	6.70
45	5.25	5.61	5.97	6.31	6.62	6.90	7.14
50	-	5.69	6.10	6.51	6.90	7.27	7.60
55	-	-	6.21	6.70	7.17	7.63	8.07
60	-	-	-	6.87	7.44	7.99	8.54
65	-	-	-	7.03	7.69	8.36	9.01

# R.E.S.L

## Richmonds Earl Shilton Limited

Specialist Distributors of Compressors and Refrigeration Spares

### Model: MTZ50

#### Mass flow [kg/s]

Capacity

$t_c \setminus t_e$	-15	-10	-5	0	5	10	15
35	98.20	130.65	168.76	213.14	264.40	323.15	390.00
40	91.31	123.76	161.77	205.94	256.88	315.20	381.51
45	84.56	116.66	154.21	197.82	248.09	305.64	371.08
50	-	109.43	146.18	188.88	238.14	294.57	358.78
55	-	-	137.77	179.22	227.12	282.08	344.72
60	-	-	-	168.92	215.11	268.26	328.98
65	-	-	-	158.09	202.22	253.21	311.66

#### C.O.P. [W/W]

$t_c \setminus t_e$	-15	-10	-5	0	5	10	15
35	2.16	2.63	3.17	3.80	4.55	5.47	6.62
40	1.86	2.29	2.77	3.31	3.95	4.71	5.63
45	1.60	1.99	2.41	2.88	3.41	4.04	4.78
50	-	1.72	2.09	2.49	2.93	3.45	4.04
55	-	-	1.80	2.14	2.51	2.93	3.40
60	-	-	-	1.82	2.13	2.46	2.85
65	-	-	-	1.54	1.78	2.06	2.36

Operating conditions: suction superheat: 11.1 K, subcooling: 8.3 K

$t_c$  - Condensing temperature [°C]

$t_e$  - Evaporating temperature [°C]

#### Application range

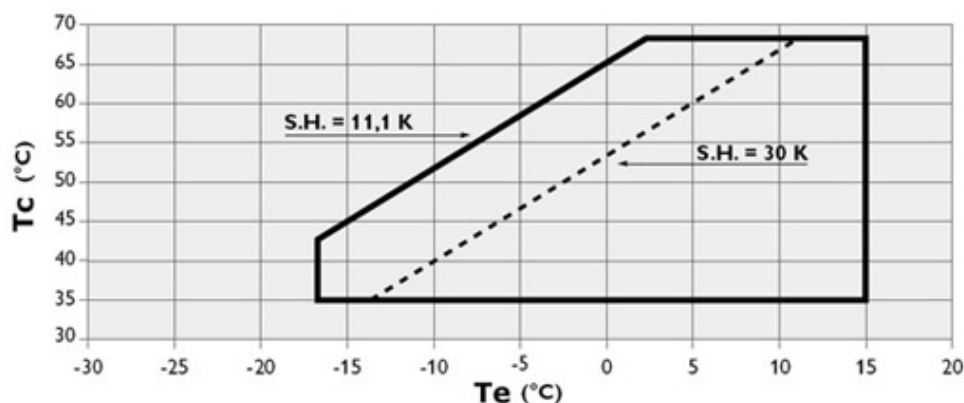

# R.E.S.L

**Richmonds Earl Shilton Limited**

**Specialist Distributors of Compressors and Refrigeration Spares**

## **Model: MTZ50**

### **Dimensions**

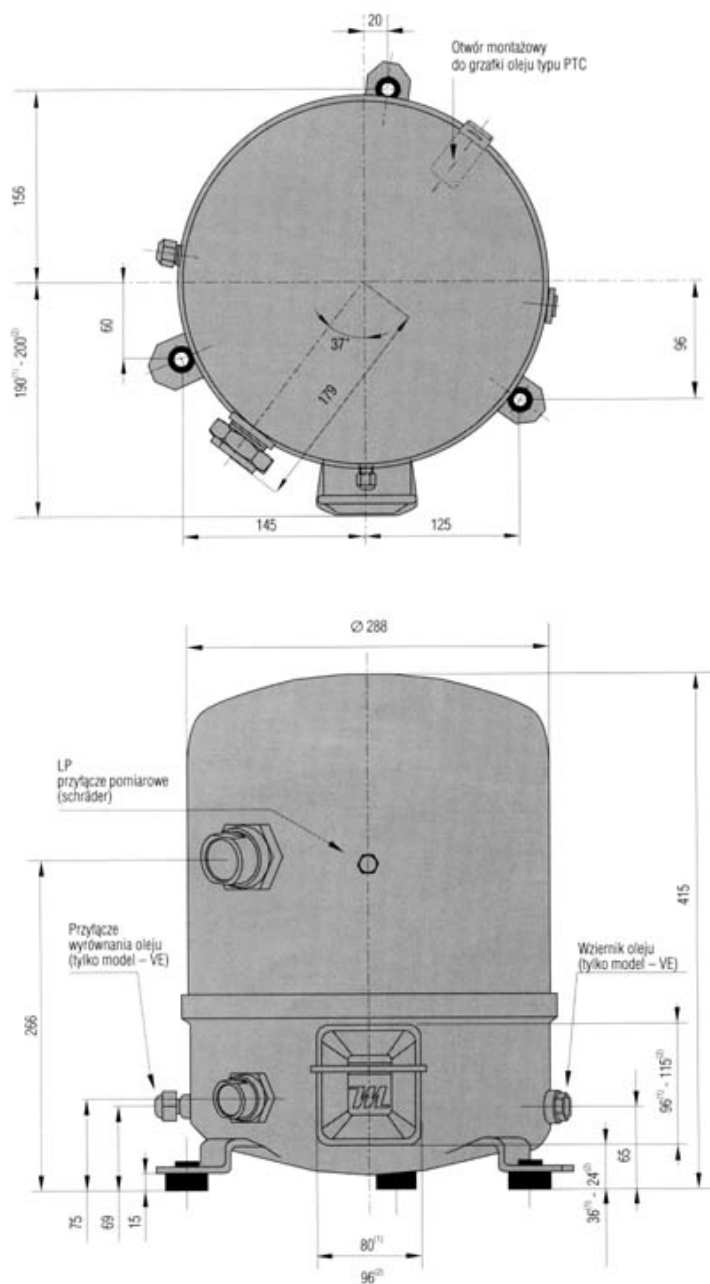



# R.E.S.L

**Richmonds Earl Shilton Limited**

**Specialist Distributors of Compressors and Refrigeration Spares**

**Model: MTZ50**

**Image**



# R.E.S.L

**Richmonds Earl Shilton Limited**

**Specialist Distributors of Compressors and Refrigeration Spares**

**Model: MTZ50**

**Electrical**

## Single phase power supply

### Electrical data

Motor voltage code:	1	5
Starting current [A]:	114	92
Maximum Continuous Current (MCC) [A]:	36	29
Winding resistance (between phases) (run/start) [ $\Omega$ ]:	0,37/1,79	0,52/2,65

### PSC starting with additional winding

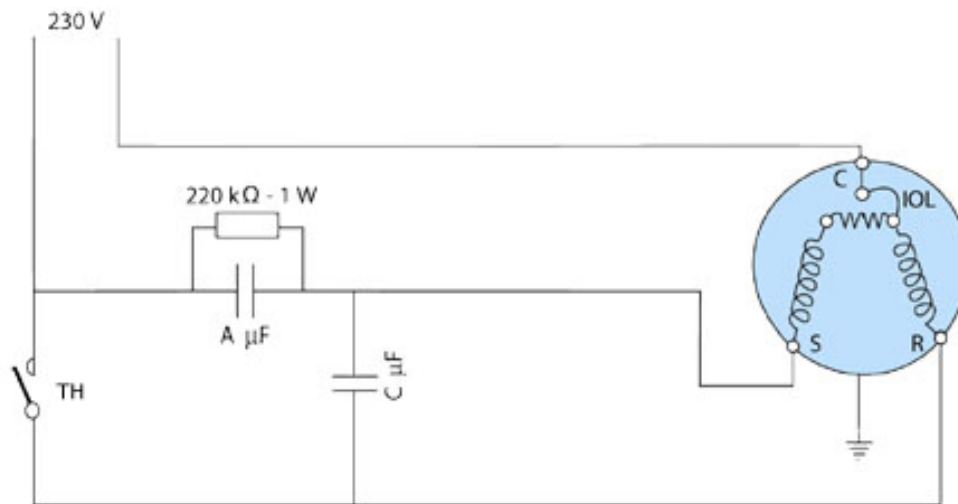

IOL: inner motor protection (klixon)

A, C: main condensers

C: starting condenser / S: common

TH: thermostat

SR: movement transmitter

# R.E.S.L

**Richmonds Earl Shilton Limited**

**Specialist Distributors of Compressors and Refrigeration Spares**

**Model: MTZ50**

**Electrical**

## CSR starting with additional winding

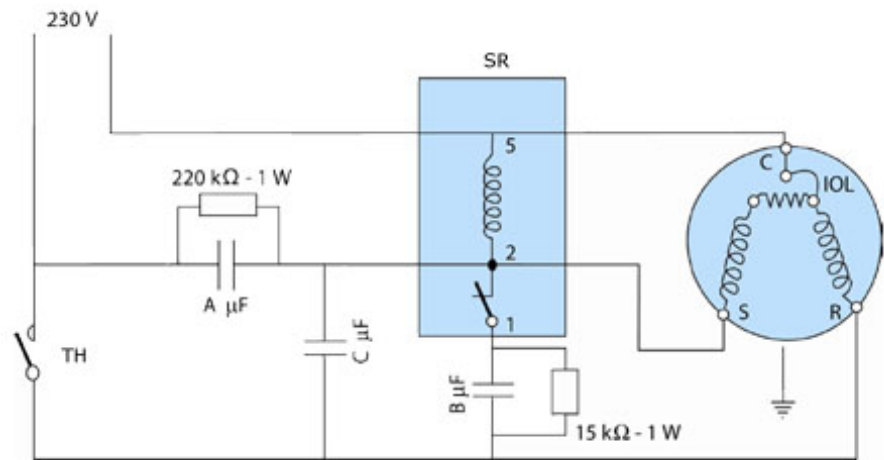

IOL: inner motor protection (klixon)

A, C: main condensers

B: starting condenser

C: common / S: additional starting winding

TH: thermostat

SR: movement transmitter

## CSR starting without additior

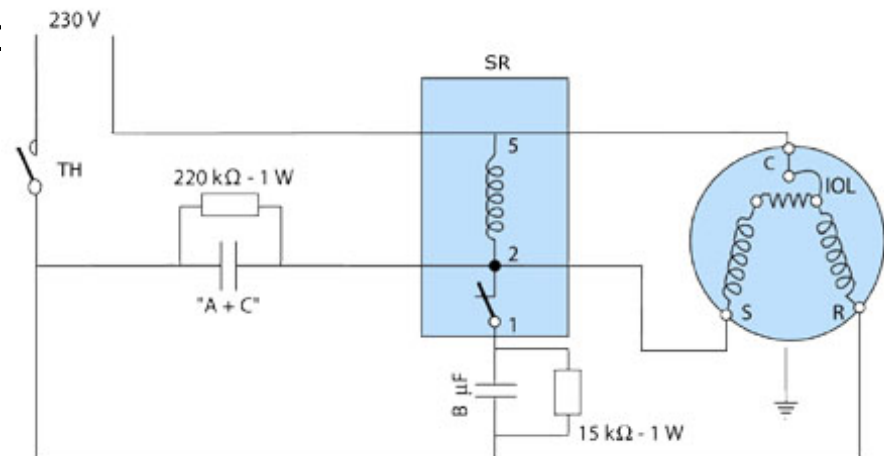

IOL: inner motor protection (klixon)

A, C: main condensers

B: starting condenser

C: common / S: additional starting winding

TH: thermostat

SR: movement transmitter

condensers A and C are replaced by one condenser of capacity A + C

# R.E.S.L

## Richmonds Earl Shilton Limited

Specialist Distributors of Compressors and Refrigeration Spares

### Model: MTZ50

Electrical

### Three-phase power supply

#### Electrical data

Motor voltage code:	3	4	6	7	9
Starting current [A]:	115	42	77	44	78
Maximum Continuous Current (MCC) [A]:	25	12	77	10	13,5
Winding resistance (between phases) [ $\Omega$ ]:	0,72	3,8	1,39	5,83	1,68

### Connection diagram for systems without refrigerant suction

TH: Thermostat

180 s: Optional short cycle timer (3min) 5 pts

KA: Control relay

LLSV: Liquid Solenoid valve

KM: Compressor contactor

KS: Safety lock out relay

BP: Low pressure switch

HP: High pressure switch

Q1: Fused disconnect

F1: Fuses

F2: External overload protection

M: Compressor's engine

thM: Motor safety thermostat

DGT: Discharge gas thermostat

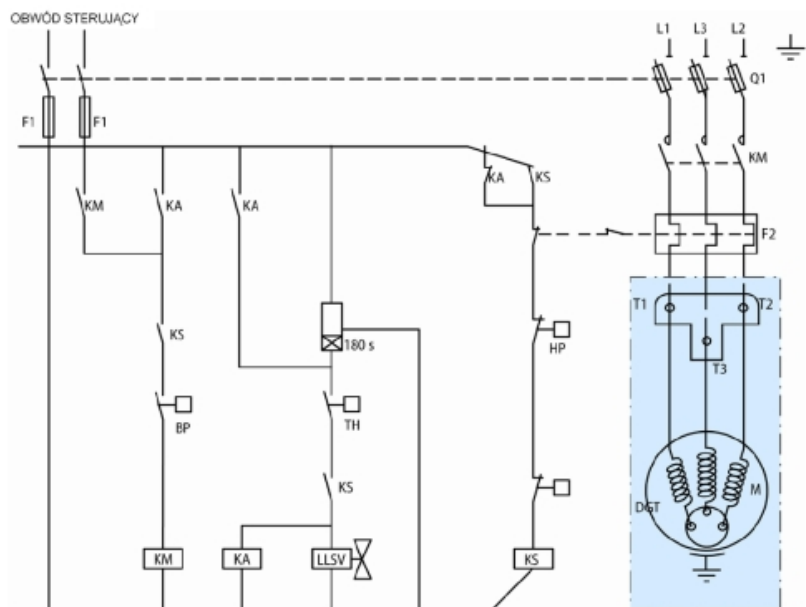

# R.E.S.L

**Richmonds Earl Shilton Limited**

**Specialist Distributors of Compressors and Refrigeration Spares**

**Model: MTZ50**

**Electrical**

## Connection diagram for systems with refrigerant suction

- TH: Thermostat
- 180 s: Optional short cycle timer (3min) 5 pts
- KA: Control relay
- LLSV: Liquid Solenoid valve
- KM: Compressor contactor
- KS: Safety lock out relay
- BP: Low pressure switch
- HP: High pressure switch
- Q1: Fused disconnect
- F1: Fuses
- F2: External overload protection
- M: Compressor's engine
- thM: Motor safety thermostat
- DGT: Discharge gas thermostat

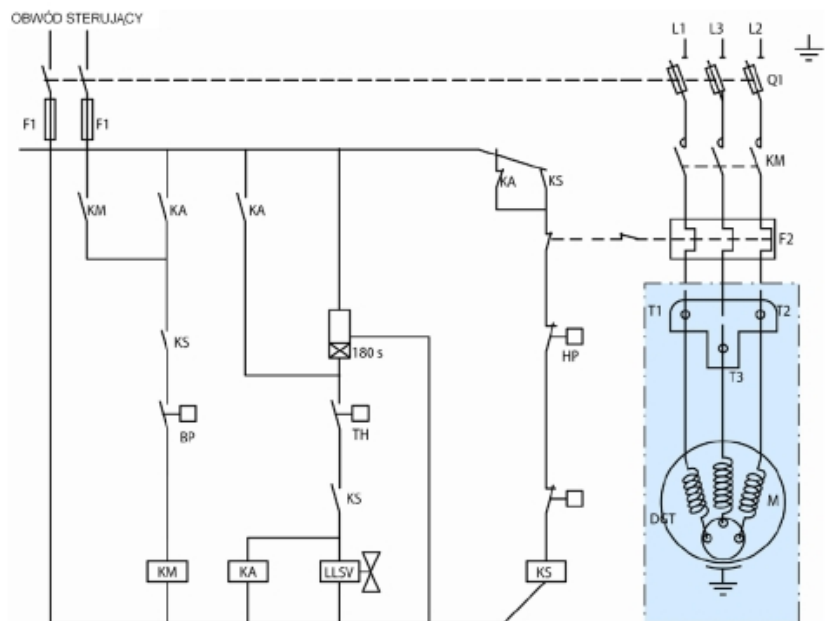

# R.E.S.L

**Richmonds Earl Shilton Limited**

**Specialist Distributors of Compressors and Refrigeration Spares**

## **Model: MTZ50**

### **Equipment**

#### **Equipment**

- ▶ crankcase heater - PTC 35 W
- ▶ belt type heater - crankcase heater 65W, 230V
- ▶ Rotolock valves
  - suction: Rotolock valve connection 1 3/4", connection with supplied sleeve 7/8"
  - discharge: Rotolock valve connection 1 1/4", connection with supplied sleeve 3/4"
- ▶ soft-start kit - electronic softstart MCI 15C
- ▶ acoustic hood - acoustic shield of Danfoss catalogue number 7755002