



INDICATIVE PHOTO

General features : RS2100B

RS range unit coolers have been designed to be installed inside cold rooms suited for fresh and frozen goods storage.

Their shape, being extremely compact, make their installation possible also in cold rooms having very small dimensions

RS range unit coolers are available in two main versions: the one suited for high temperature (differentiated fin spacing 3,5/7mm); the other version suited for medium and low temperature application (differentiated fin spacing 4,5/9mm).

In models for high temperature the version with the fitted defrosting heater is not available; for these models the heaters are optional items and they will be supplied not mounted.

The models for medium and low temperature application are available in the version supplied without defrosting heater (mod. RS...B) and with defrosting heater mounted and wired on the unit cooler's terminal box as well (mod. RS...BED).

The coil is made of aluminium fins and 3/8" copper tube with geometry 25x22

It is tested with nitrogen at a pressure of 25 bar

The fan motor models in use have the following features:

Manufactured following EN 60335-1 laws, with internal thermal protection

Draw through air flow

Fan guard made of plastic and brackets made of steel

Fan diameter 200mm, 34° inclination

Power supply 220-240V/1/50-60Hz

IP42 protection rate

Operating temperature from -40°C to +40°C

B insulation class

It is tested with nitrogen at a pressure of 25 bar

The housing is made of aluminium

The manufacturing solutions used give the housing strength and guarantee the absence of vibrations during the functioning.

Screws, washers and nuts are made of stainless steel

The B and BED models are supplied with fitted drip tray



INDICATIVE PHOTO

Product file : Unit coolers

Code	RS2100BED
Model	Ceiling
Range	RS
Application	LBP
Net weight	7 kg
Inlet connection	9.52 mm
Outlet connection	9.52 mm
Drain connection	1/2" Gas (20mm)
Ped	0
Rows	4
Fin spacing	4,5/9
Circuit volume	0,6 dm ³
Total surface	1,94 m ²

Fan motor

Type	AC
Fans no.	2
Diameter	200 mm
Power supply	220-240/1/50-60
Defrost	600 W
Speed	1300 rpm
Power consumption	86 W
Current consumption	0,5 A
Air flow	426 m ³ /h
Air throw	3 m

Technical drawing - RS2100B

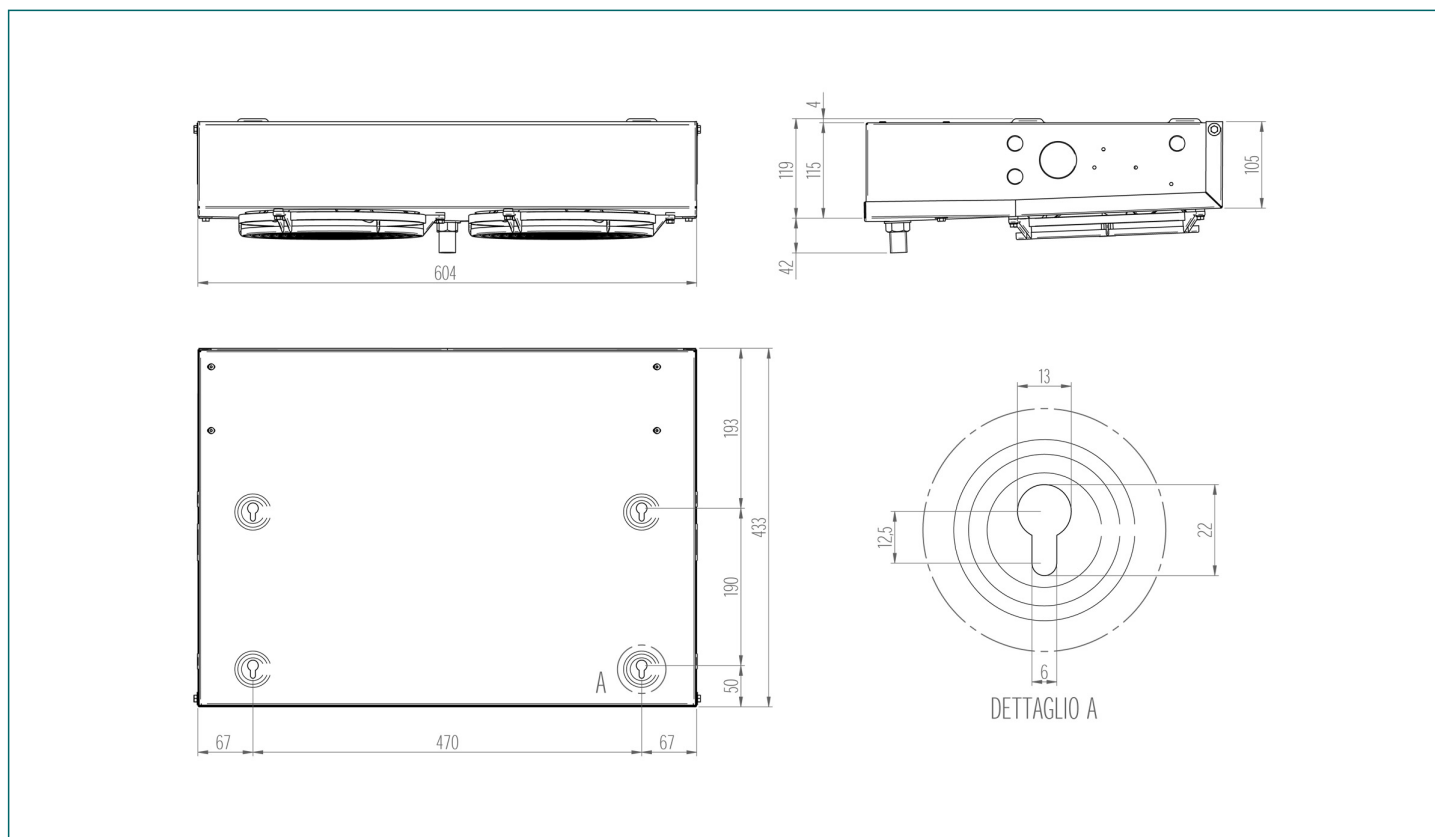

Refrigerating capacity table (watt) - Gas : R404A

dT \ Tc	-40°C	-35°C	-30°C	-25°C	-20°C	-15°C	-10°C	-5°C	0°C
10	409	459	509	543	579	610	629	663	703
9	385	420	455	488	516	542	558	587	623
8	348	376	404	429	450	471	484	509	541
7	308	327	346	365	382	390	408	429	456
6	253	269	285	298	310	317	331	348	372
5	199	208	217	225	233	237	249	263	281